

GCSE Mathematics

1MA1



Problem-solving questions 1

Higher Tier: Gold

Time: 1 hour 30 minutes

You should have: Ruler graduated in centimetres and millimetres, protractor, pair of compasses, pen, HB pencil, eraser. Tracing paper may be used.

Calculator permitted

Questions with * could also be seen on Foundation Tier

1. The diagrams below shows the number of line segments needed to join a set of n points.



$n = 1$

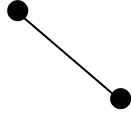

$n = 2$

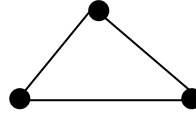

$n = 3$

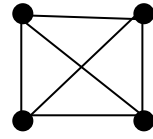

$n = 4$

The number of line segments joining the set of points forms a sequence.

Find an expression in terms of n for the number of line segments joining n points.

(Total for question 1 is 3 marks)

- *2. The diagram shows the floor plan of a stage.
The stage floor is in the shape of a rectangle $ABCD$ and a trapezium $ADEF$.

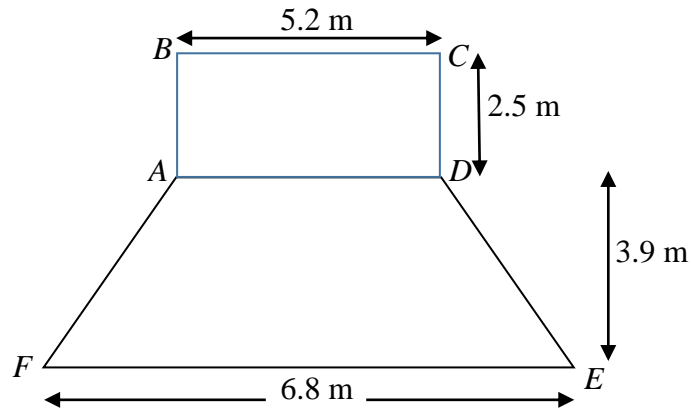

$AB = 5.2$ m.

$CD = 6.8$ m.

The height of the trapezium is 3.9 m.

The manager is going to varnish the stage floor with one coat.

The varnish is sold in tins.

One tin will cover 3.5 m^2

One tin normally costs £26.40

The table shows the discount the manager receives

Number of tins bought	Discount
1 – 4	5%
5 – 10	7.5%
11 or more	15%

Work out the total cost of the tins.

(Total for question 2 is 6 marks)

- *3. Here is a diagram of a black circle inside a white square and a diagram of a small grey square inside a white square.
The two white squares are the same size.

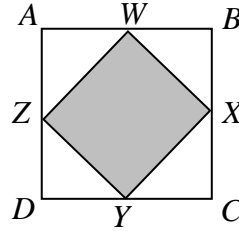
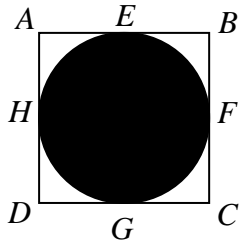

$$AB = 8x.$$

The sides of the square are tangents to the circle at the points E , F , G and H .
 W , X , Y and Z are the midpoints of AB , BC , CD and DA respectively.

Work out the ratio of the area of the black circle to the area of the white square to the area of the grey square. Give your answer in its simplest form.

(Total for question 3 is 4 marks)

4. David wants to measure the width of a road

He chooses two points, A and B , 40 m apart.

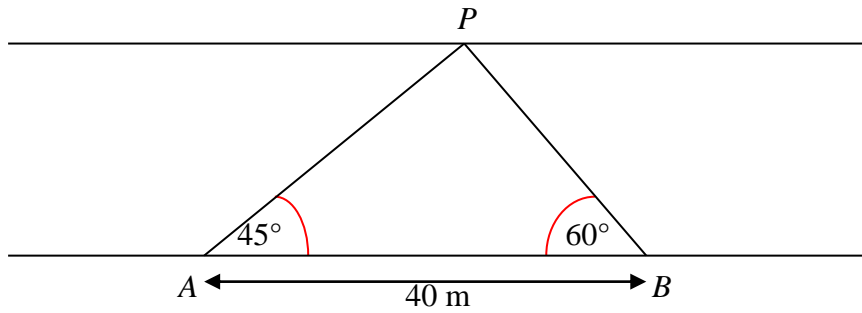

The angles made with a lamppost, P , on the opposite side are measured.

Angle $BAP = 45^\circ$

Angle $ABP = 60^\circ$

Work out the width, in metres, of the road. Give your answer correct to 3 significant figures.

(Total for question 4 is 4 marks)

5. Ravina has a large number of coins in a jar.
All the coins in the jar are 50p coins.

She wants to find an estimate for the total amount of money in the jar.

Ravina takes a sample of 50 coins from the jar and marks each one with a marker.
She then puts the coins back into the jar.

Ravina then shakes the jar.

She now takes a sample of 30 coins from the jar and sees that 12 of them are marked.

Work out an estimate for the total amount of money in the jar.

(Total for question 5 is 4 marks)

6. The time, t seconds, of oscillation for a simple pendulum is given by the formula

$$2\pi\sqrt{\frac{l}{g}}$$

where

$g = 9.8 \text{ m/s}^2$, measured correct to 1 decimal place,

$l = 1.31 \text{ m}$, measured correct to 3 significant figures.

By considering bounds, work out the value of t to a suitable degree of accuracy.

You must show your working and give a reason for your final answer.

(Total for question 6 is 5 marks)

7. A cylinder has base radius $2x$ and height $3x$.
A cone has base radius $3x$ and height h .

All measurements are in cm.

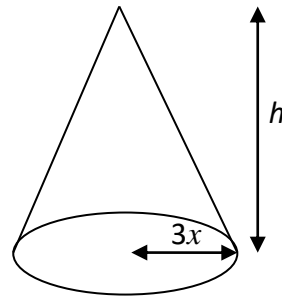
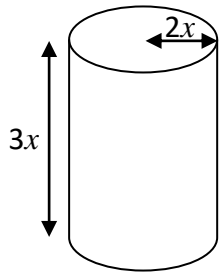

The volume of the cylinder and the volume of the cone are equal.

Find h in terms of x . Give your answer in its simplest form.

(Total for question 7 is 3 marks)

8. The diagram shows a placard.

AD is a chord of a circle centre O .

The radius of the circle is 40 cm.

Angle $AOD = 70^\circ$

$ABCD$ is a square.

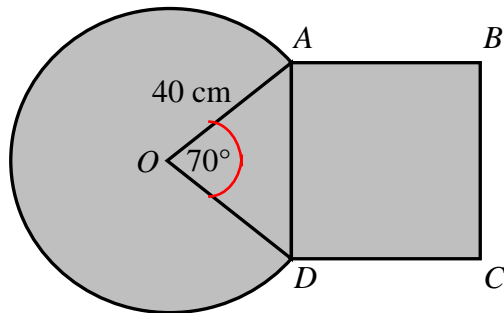

Work out the area, in cm^2 , of the placard.

Give your answer correct to 3 significant figures.

(Total for question 8 is 5 marks)

9. Helena has 7 oranges, 10 plums and 4 pears in her fruit bowl.
She can choose from the following selections

an orange and a plum, or

a plum and a pear, or

an orange, a plum and a pear.

How many different ways can Helena choose a fruit from the bowl?

(Total for question 9 is 3 marks)

10. The diagram shows a cross section of a ski resort in a valley.

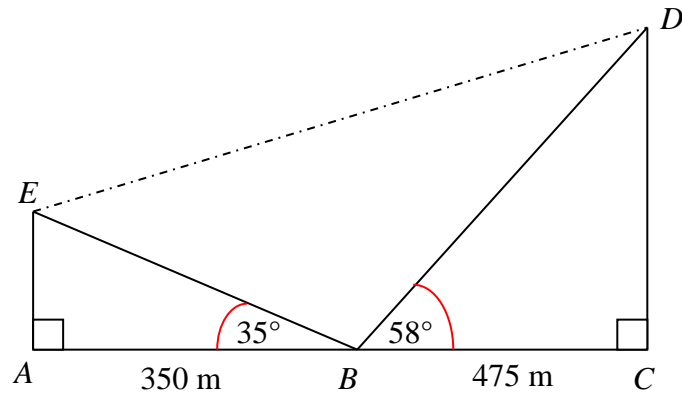

The line ABC is horizontal.

AE and CD are two vertical cliffs.

A ski lift cable joins D to E .

Work out the length of the ski lift cable. Give your answer correct to 3 significant figures.

(Total for question 10 is 4 marks)

11. Here is a sketch of a cross section of a toy.

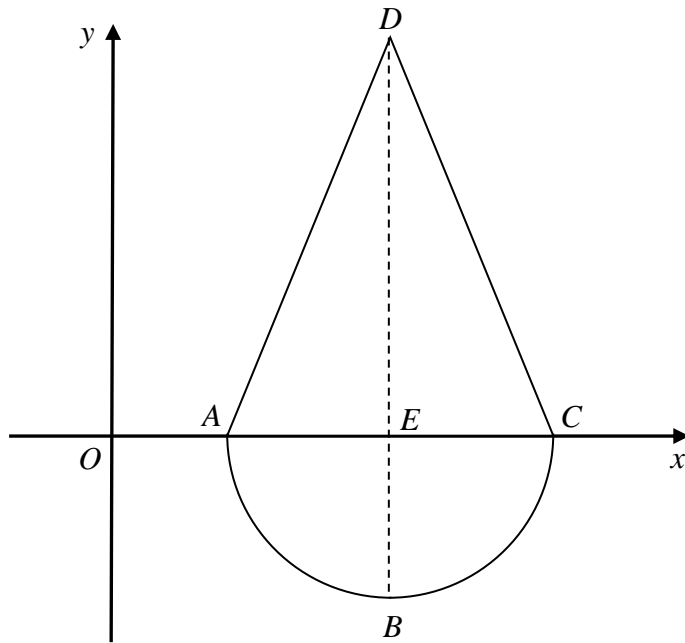

The curve has equation $y = x^2 - 14x + 40$ where x and y are measured in centimetres.

BED is a straight line.

The ratio of the length BE to the length ED is 3:5

Work out the area of triangle ADC .

(Total for question 11 is 5 marks)

12. For all values of x ,

$$f(x) = x^2 + 1$$

$$g(x) = 3x - 4$$

(a) Find $g^{-1}(x)$.

(b) Solve $fg(x) = gf(x)$.

(2)

(4)

(Total for question 12 is 6 marks)

13. Megan has two boxes.

There are x beads in box A.
7 of these beads are white.
The rest of the beads are black.

There are x beads in box B.
4 of these beads are white.
The rest of the beads are black.

She chooses at random a bead from box A.

She notes the colour and then places this bead into box B.

She then chooses at random a bead from box B.

The probability of choosing a white bead from box A and a white bead from box B is $\frac{7}{22}$

Work out the total number of beads in the two boxes.

(Total for question 13 is 5 marks)

14. The histogram gives information about the heights, in centimetres, of some tomato plants.

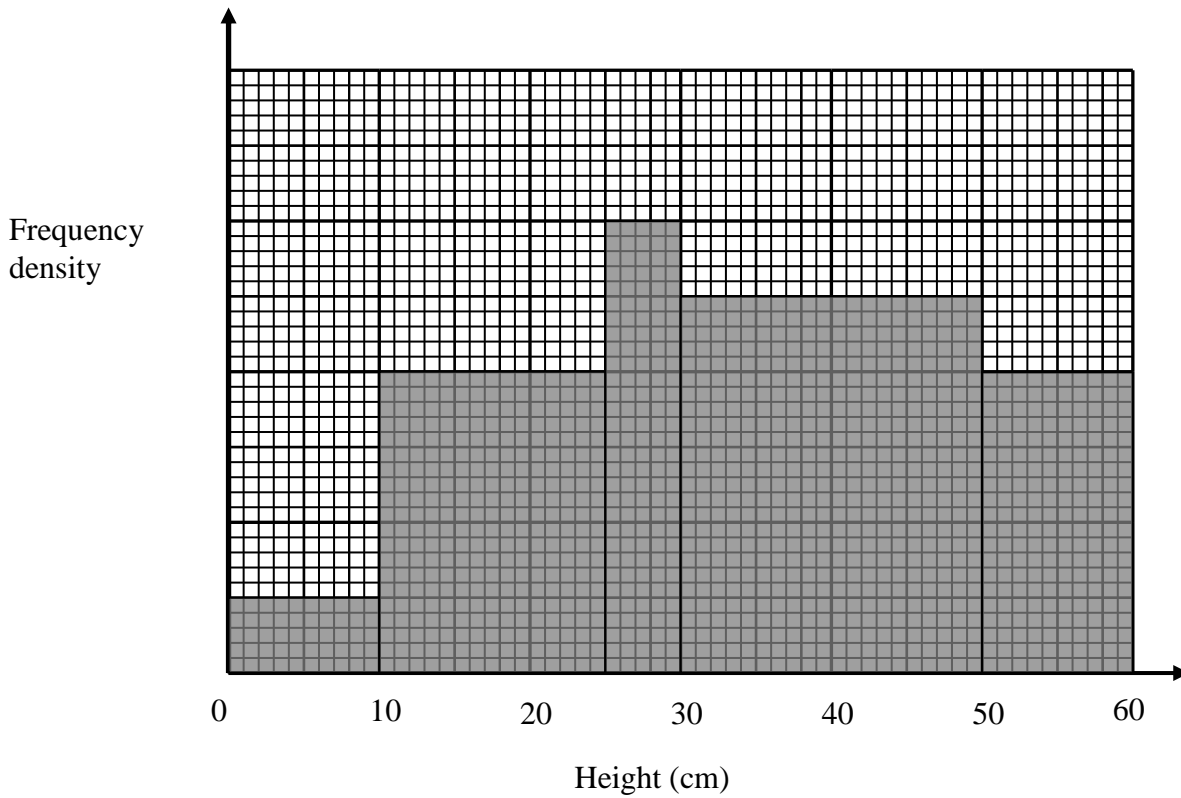

There are 15 tomato plants with a height between 25 cm and 30 cm.

Work out the fraction of tomato plants that are between 30 cm and 50 cm.

(Total for question 14 is 3 marks)

15. Harry buys a laptop for £364

He wants to put a tag with a price on the laptop so that in the sale he can give a discount of 30% off the price on the tag and still make a profit of 20% on the price he paid for the laptop.



Work out the price that Harry should put on the tag.

(Total for question 15 is 3 marks)

Higher Tier Problem solving questions – Mark schemes

Qn	Answer	Mark	Notes
1	$\frac{1}{2}n^2 - \frac{1}{2}n$	3	<p>P1 process for correct deduction from differences e.g. second difference of 1 implies $\frac{1}{2}n^2$</p> <p>P1 for $\frac{1}{2}n^2$ as part of an algebraic expression e.g. $\frac{1}{2}n^2 \pm C$</p> <p>A1 for correct answer oe</p>
*2	£246.84	6	<p>P1 process to find the area of the trapezium e.g. $\frac{1}{2}(5.2 + 6.8) \times 3.9 (= 23.4)$</p> <p>P1 process to find the total area of the stage e.g. “23.4” + $(5.2 \times 2.5 = (13)) (= 36.4)$</p> <p>P1 process to find the number of tins e.g. “36.4” $\div 3.5 (= 10.4)$</p> <p>P1 process to find cost of the total number of tins or uses correct discount to find cost of one tin e.g. “11” $\times 26.40$ or 0.85×26.40</p> <p>P1 process to find total cost e.g. “11” $\times 26.40 \times 0.85$</p> <p>A1 answer 246.84</p>
*3	$\pi:4:2$	4	<p>P1 process to write the areas in ratio form for white square and black circle e.g. $64x^2:16\pi x^2$ or $16\pi x^2: 64x^2$</p> <p>P1 process to write the areas in ratio form for white square and grey square e.g. $64x^2:32x^2$ or $32x^2: 64x^2$</p> <p>P1 strategy to start to combine the ratios e.g. $4:\pi$ and $4:2$</p> <p>A1 cao</p>

Qn	Answer	Mark	Notes
4	25.3 – 25.4	4	<p>P1 process to find length PA or PB</p> $\frac{PB}{\sin 45} = \frac{40}{\sin 75} \text{ or } \frac{PA}{\sin 60} = \frac{40}{\sin 75}$ <p>P1 process to find PA or PB</p> <p>e.g. $PB = \frac{40}{\sin 75} \times \sin 45$ or $PA = \frac{40}{\sin 75} \times \sin 60$</p> <p>or 29.28..... or 35.86.....</p> <p>P1 process to find perpendicular at point P</p> <p>e.g. $\sin 60 = \frac{\text{perp}}{29.28..}$ or $\sin 45 = \frac{\text{perp}}{35.86..}$</p> <p>A1 for in the range 25.3 – 25.4</p>
5	£62.50	4	<p>P1 process to set up the equation</p> <p>e.g. $\frac{50}{n} = \frac{12}{30}$</p> <p>P1 process to find the value of n</p> <p>e.g. $n = \frac{50 \times 30}{12}$</p> <p>P1 process to find total amount of money in the jar,</p> <p>e.g. “125” \times 50p</p> <p>A1 cao</p>
6	2.3 and correct reason	5	<p>B1 finding bounds of l: 1.315 or 1.305</p> <p>finding bounds of g: 9.85 or 9.75</p> <p>P1 use of ‘upper bound’ and ‘lower bound’ in equation</p> <p>e.g. $2\pi\sqrt{\frac{1.315 \text{ or } 1.305}{9.85 \text{ or } 9.75}}$</p> <p>P1 process of choosing correct bounds</p> <p>e.g. $2\pi\sqrt{\frac{1.315}{9.75}}$ or $2\pi\sqrt{\frac{1.305}{9.85}}$</p> <p>A1 for 2.3074493..... and 2.2870044..... from correct working</p> <p>C1 for 2.3, since both upper and lower bound round to 2.3</p>
7	$h = 4x$	3	<p>P1 process to find volume of cylinder or volume of cone</p> <p>e.g. $\pi \times (2x)^2 \times 3x$ or $\frac{1}{3} \pi \times (3x)^2 \times h$</p> <p>P1 process to solve equation</p> <p>e.g. $\pi \times (2x)^2 \times 3x = \frac{1}{3} \times \pi \times (3x)^2 \times h$</p> <p>A1 cao</p>

Qn	Answer	Mark	Notes
8	6910	5	<p>P1 process to find the area of major segment AOD e.g. $\pi \times 40^2 \times \frac{290}{360}$ (= 4049.163....)</p> <p>P1 process to find area of triangle AOD e.g. $\frac{1}{2} \times 40^2 \times \sin 70$ (= 751.754....)</p> <p>P1 process to find length of chord AD e.g. $40^2 \times 40^2 - (2 \times 40 \times 40 \times \cos 70)$ (= 2105.53) or $\sqrt{21053..}$ or 45.886...</p> <p>P1 process to find shaded area e.g. “4049.163....” + “751.754....” + “2105.53” A1 for 6910</p>
9	390	3	<p>P1 process to find number of ways e.g. 7×10 or 10×4 or $7 \times 10 \times 4$</p> <p>P1 complete process to find the total number of fruits e.g. $7 \times 10 + 10 \times 4 + 7 \times 10 \times 4$ A1 cao</p>
10	972 – 973	4	<p>P1 process to find the length of one side e.g. $AE = 350 \tan 35^\circ$ (= 332.59 ...) or $CD = 475 \tan 58^\circ$ (= 760.15...) or $\cos 35 = \frac{350}{BE}$ or $\cos 58 = \frac{475}{BD}$</p> <p>P1 process to find the difference between AE and CD e.g. “760.15...” – “245.07...” (= 515.08....) or process to find BE and BD e.g. $BE = \frac{350}{\cos 35}$ (= 427.27.....) and $BD = \frac{475}{\cos 58}$ (= 896.36.....)</p> <p>P1 complete process to find ED e.g. $\sqrt{51508..^2 + 823^2}$ or “427.27”² + “896.36”² – (2 × “427.27” × “896.36” × cos 87 A1 for answer in the range 972 – 973</p>

Qn	Answer	Mark	Notes
11	45	5	<p>P1 process to complete the square or to factorise e.g. $(x-7)^2$ or $(x-4)(x-10)$</p> <p>P1 process to find the y value of point B e.g. $(x-7)^2 - 9$ or $[7^2 - 14(7) + 40]$ ($= -9$)</p> <p>P1 for a strategy to find the length of DE e.g. $DE = 9 \div 3 \times 5$ ($= 15$)</p> <p>P1 process to find area of triangle e.g. $(“10 - 4” \times “15”) \div 2$</p> <p>A1 cao</p>
12 (a)	$\frac{x+4}{3}$	2	<p>M1 for correct method to find inverse function e.g. $x = 3y - 4$ or $x = \frac{y+4}{3}$</p> <p>A1 for answer oe</p>
12 (b)	1,3	4	<p>P1 process to find fg(x) and gf(x) and form an equation e.g. $9x^2 - 24x + 17 = 3(x^2 + 1) - 4$</p> <p>P1 process to reduce the equation to $ax^2 + bx + c = 0$ e.g. $6x^2 - 24x + 18 = 0$ oe</p> <p>P1 process to solve quadratic equation e.g. $(x-1)(x-3) = 0$</p> <p>A1 cao</p>
13	20	5	<p>P1 process to find $\frac{7}{x}$ or $\frac{5}{x+1}$</p> <p>P1 process to find $\frac{7}{x} \times \frac{5}{x+1} = \frac{7}{22}$</p> <p>P1 beginning to process the algebra to obtain $x^2 + x - 110 = 0$</p> <p>P1 process to solve the quadratic equation e.g. $(x+11)(x-10) = 0$</p> <p>A1 for cao</p>

Qn	Answer	Mark	Notes
14	$\frac{5}{12}$	3	<p>P1 for frequency \div class width or correct scale on FD axis or use of area, e.g. $15 \div 5$</p> <p>P1 for correct method to find area of all remaining bars condone one error</p> <p>e.g. $(0.5 \times 10) + (2 \times 15) + (15) + (2.5 \times 20) + (2 \times 10)$</p> <p>A1 for $\frac{5}{12}$ oe</p>
15	624	3	<p>P1 for a process to increase the price using 20%</p> <p>e.g. $364 \times 1.2 (= 436.8)$</p> <p>P1 for a process to increase the price using 30%</p> <p>e.g. “436.8” $\div 0.7$</p> <p>A1 cao</p>