

Bearings

Video 26 on Corbettmaths

Question 5: Give these directions of travel as three figure bearings

- | | | | |
|-----------|----------------|-----------|----------------|
| (a) North | (b) South-east | (c) West | (d) North-east |
| (e) East | (f) South-west | (g) South | (h) North-west |

Question 6: A dolphin is on a bearing of 100° from the island.
 The same dolphin is on a bearing of 015° from the lighthouse.
 On a sketch of the diagram below, mark the location of the dolphin.



Question 7: A hot-air balloon is on a bearing of 140° from the radar A.
 The same hot-air balloon is on a bearing of 065° from the radar B.
 On a sketch of the diagram below, mark the location of the hot-air balloon.



Bearings

Video 26 on Corbettmaths

Question 8: A UFO is on a bearing of 015° from the radar A.
The same UFO is on a bearing of 315° from the radar B.
On a sketch of the diagram below, mark the location of the UFO.



Question 9:

- (a) The bearing of A from B is 025° , find the bearing of B from A.
- (b) The bearing of A from B is 061° , find the bearing of B from A.
- (c) The bearing of A from B is 098° , find the bearing of B from A.
- (d) The bearing of A from B is 102° , find the bearing of B from A.
- (e) The bearing of A from B is 193° , find the bearing of B from A.
- (f) The bearing of A from B is 222° , find the bearing of B from A.
- (g) The bearing of A from B is 315° , find the bearing of B from A.

Question 10: Make a copy of the diagram below into your book.



- (a) Find the bearing of B from A.
- (b) Find the bearing of A from B.

Use the scale 1cm represents 20miles.

- (c) From your diagram, work out the real distance between A and B.

C is 140 miles from B on a bearing of 110° .

- (d) On your diagram, mark C with a cross.

Changing the Subject: Advanced

Video 8 on www.corbettmaths.com

Question 3: Make c the subject of the following

(a) $w = \frac{ac}{a - c}$

(b) $w = 6 + \frac{a}{c + 2}$

Apply

Question 1: The cosine rule is $a^2 = b^2 + c^2 - 2bc \cos A$.
Make $\cos A$ the subject.

Answers



Click here



Scan here

Forming and Solving Equations

Hard example

ABCH is a square. HCFG is a rectangle. CDEF is a square.

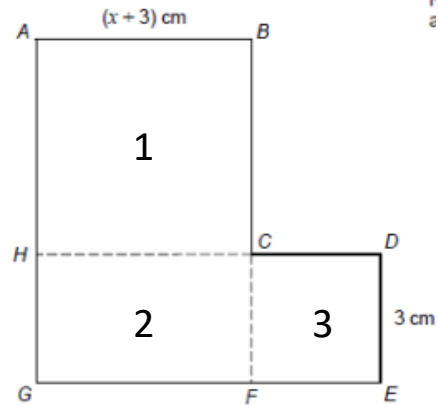

Show that the total area of the L-shape in cm^2 is $x^2 + 9x + 27$

$$\begin{aligned} \text{Area of square 1: } & (x+3) \times (x+3) \\ & = (x+3)(x+3) \\ & = x^2 + 6x + 9 \end{aligned}$$

Remember when you multiply two expressions like this together it forms double brackets

$$\begin{aligned} \text{Area of rectangle 2: } & 3 \times (x+3) \\ & = 3x + 9 \end{aligned}$$

$$\text{Area of square 3: } 3 \times 3 = 9$$

$$\begin{aligned} \text{Total area} & = x^2 + 6x + 9 + 3x + 9 + 9 \\ & = x^2 + 9x + 27 \end{aligned}$$

$$(2x - 9)$$



$$(x - 2)$$

The area of this shape is 42cm^2 .

Form an equation for the area of this shape
Solve this equation and obtain a suitable value for x

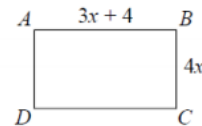

ABCD is a rectangle. EFGH is a trapezium.

All measurements are in centimetres.

The perimeters of these two shapes are the same.

Work out the area of the rectangle.

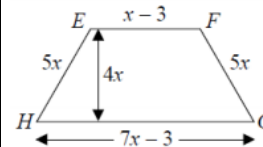

$$x+2$$



The area of this shape is 36cm^2 .
Find the value of x .

$$(x+7)$$



$$(x - 2)$$

The area of this shape is 22cm^2 .
Find the value of x .

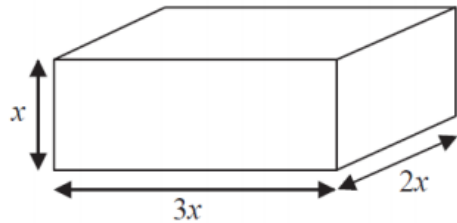

All measurements are in centimetres.
 x is an integer.
 The total volume of the cuboid is less than 900cm^3
 Show that $x \leq 5$

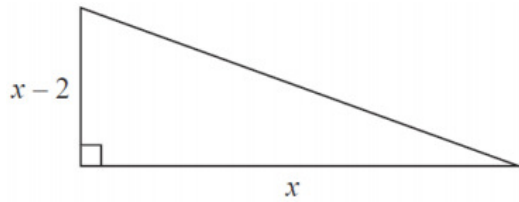

The area of the triangle is 2.5 cm^2 .
 Find the perimeter of the triangle. Give your answer correct to 3 significant figures.

Mixed exam questions

Q1. June 2015 unit 1

Here is a shape.

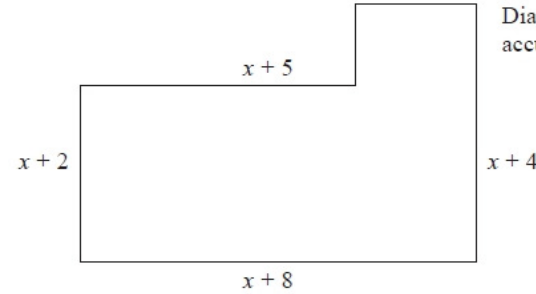

Diagram NOT accurately drawn

All the measurements are in centimetres. All the corners are right angles.
 The area of the shape is $A\text{ cm}^2$.
 Find a formula for A in terms of x .
 Give your answer in its simplest form.

$A = \dots\dots\dots$

(Total for question = 4 marks)

Q2. June 2014 unit 1

* This shape is a solid prism. The cross section of the prism is a trapezium.

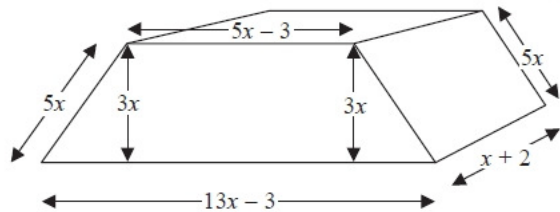

Diagram NOT accurately drawn

Show that the total surface area of the prism is $82x^2 + 32x - 12$

(Total for Question is 4 marks)

Q3. November 2014 paper 1

The diagram shows the plan of a floor.

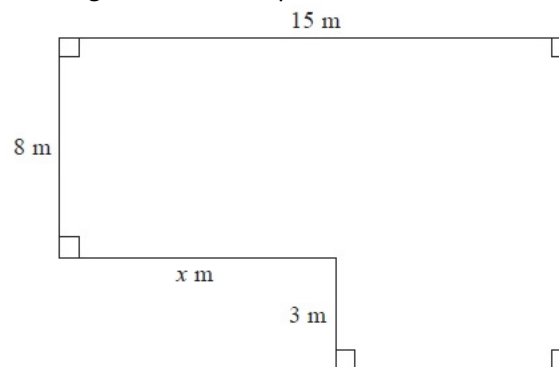

Diagram NOT accurately drawn

The area of the floor is 138 m^2 .

Work out the value of x .

.....
(Total for Question is 4 marks)

Examiner's Report Key notes

- Be careful when subtracting expressions. E.g. $(x + 8) - (x + 5)$ is actually $x + 8 - x - 5$.
- Remember to set out your working out carefully. Make it clear to the examiner what you are trying to calculate. On this type of question it may help to number each section of the shape.

Answers

$(x + 2)(x + 2) = 36$ $x^2 + 4x + 4 = 36$ $x^2 + 4x - 32 = 0$ $(x + 8)(x - 4) = 0$ $X = -8$ or 4 so $x = 4$	$(x + 7)(x - 2) = 22$ $x^2 + 5x - 14 = 22$ $x^2 + 5x - 36 = 0$ $(x + 9)(x - 4) = 0$ $X = -9$ or 4 so $x = 4$
$(2x - 9)(x - 2) = 42$ $2x^2 - 13x + 18 = 42$ $2x^2 - 13x - 24 = 0$ $(2x + 3)(x - 8) = 0$ so $x = 8$	
Perimeter of the rectangle: $3x + 4 + 3x + 4 + 4x + 4x = 14x + 8$ Perimeter of the trapezium: $7x - 3 + 5x + 5x + x - 3 = 18x - 6$ The perimeters are equal, so $14x + 8 = 18x - 6$ $8 = 4x - 6$ $14 = 4x$ so $x = 3.5$ Area of the rectangle = $(3x + 4) \times 4x$ $= (10.5 + 4) \times 14 = 14.5 \times 14 = 187\text{cm}^2$	
Volume = $x \times 3x \times 2x = 6x^3$ $6x^3 < 900$ $x^3 < 150$ the nearest cube number is 120, which is 5 cubed so $x \leq 5$	
$x^2 - 2x = 2.5$ $x^2 - 2x - 2.5 = 0$ Using the quadratic formula, $x = 2.87$ To find the perimeter, we need to use Pythagoras first. $X - 2 = 2.87 - 2 = 0.87$ $c^2 = 0.87^2 + 2.87^2$ $c^2 = 8.9938$ $c = 3.00$ Perimeter = $0.87 + 2.87 + 3 = 6.74\text{cm}$	

Exam questions

Q1.

Answer	Mark	Notes
$x^2 + 10x + 22$	4	M1 for $(x+8) - (x+5) (=3)$ or $(x+4) - (x+2) (=2)$ M1 for area of one rectangle eg $(x+2)(x+5) (=x^2+7x+10)$ M1 for complete method to find area e.g. $(x+2)(x+5) + 3(x+4) (=x^2+7x+10 + 3x+12)$ A1 cao

Q2.

Working	Answer	Mark	Notes
Front or Back: $\frac{1}{2} \times 3x(13x - 3 + 5x - 3)$ $= 27x^2 - 9x$ or $\frac{1}{2} (4x)(3x) + 3x(5x - 3)$ Top: $(5x - 3)(x + 2)$ $= 5x^2 + 7x - 6$ Bottom: $(13x - 3)(x + 2)$ $= 13x^2 + 23x - 6$ Each Side: $5x(x + 2)$ $= 5x^2 + 10x$ Total SA = $2(27x^2 - 9x) +$ $2(5x^2 + 10x) + (5x^2 + 7x - 6)$ $+ (13x^2 + 23x - 6)$ $= (54 + 10 + 5 + 13)x^2$ $+ (-18 + 20 + 7 + 23)x$ $+ (-6 - 6)$	$82x^2 + 32x - 12$	4	M1 finds the area of at least 2 faces (condone omission of brackets) M1 writes a correct algebraic expression for the area of at least 3 different faces M1 correct expressions for all 6 faces and adds C1 (dep on M3) for correct algebraic expression as a correct summary

Q3.

Answer	Mark	Notes
9	4	M1 for method to find area of one rectangle, eg $15 \times 8 (=120)$ or $15 \times 11 (=165)$ M1 (dep) for subtracting from/by given area, eg $(138 - "120") (=18)$ or $"165" - 138 (=27)$ M1 for final step from complete method shown, eg $15 - "18" \div 3$ or $"27" \div 3$ A1 cao OR M1 for a correct expression for the area of one rectangle, eg $(8 + 3) \times (15 - x)$ or $8 \times x$ M1 (dep) for a correct equation eg $(8 + 3) \times (15 - x) + 8 \times x = 138$ M1 for correct method to isolate x , eg $3x = 27$ A1 cao

1.

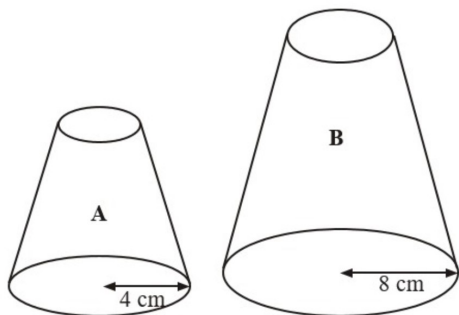

Two solid shapes, A and B, are mathematically similar.
 The base of shape A is a circle with radius 4 cm.
 The base of shape B is a circle with radius 8 cm.
 The surface area of shape A is 80 cm^2

(a) Work out the surface area of shape B. (2 marks)

The volume of shape B is 600 cm^3 .

(b) Work out the volume of shape A. (2 marks)

2.

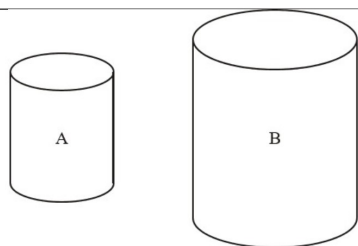

The two cylinders, A and B, are mathematically similar.
 The height of cylinder B is twice the height of cylinder A.
 The total surface area of cylinder A is 180 cm^2 .

Calculate the total surface area of cylinder B. (3 marks)

3.

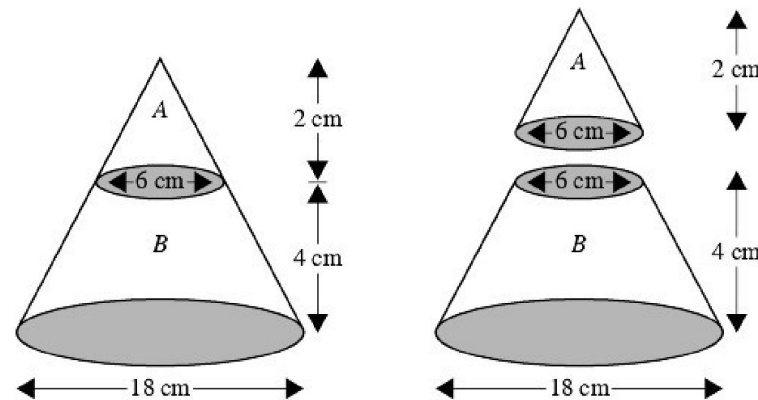

The diagram represents a large cone of height 6 cm and base diameter 18 cm.

The large cone is made by placing a small cone A of height 2 cm and base diameter 6 cm on top of a frustum B.

Calculate the volume of the frustum B.
 Give your answer in terms of π . (4 marks)

4.

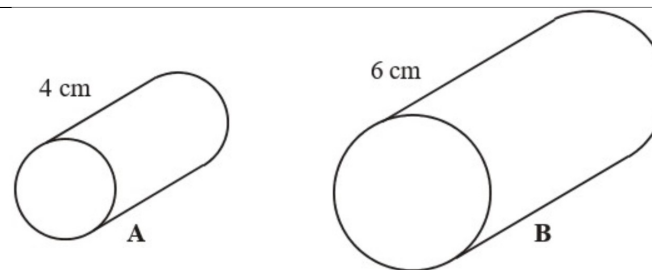

Cylinder A and cylinder B are mathematically similar.

The length of cylinder A is 4 cm and the length of cylinder B is 6 cm.

The volume of cylinder A is 80 cm^3 .

Calculate the volume of cylinder B. (3 marks)

5. X and Y are two geometrically similar solid shapes.

The total surface area of shape X is 450 cm^2 .

The total surface area of shape Y is 800 cm^2 .

The volume of shape X is 1350 cm^3 .

Calculate the volume of shape Y.

(3 marks)

6.

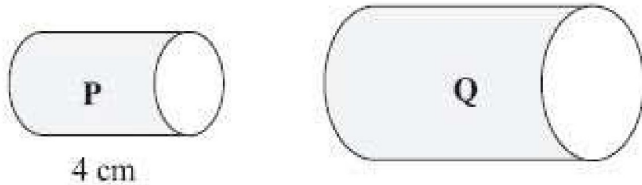

Two cylinders, P and Q, are mathematically similar.

The total surface area of cylinder P is $90\pi \text{ cm}^2$.

The total surface area of cylinder Q is $810\pi \text{ cm}^2$.

The length of cylinder P is 4 cm.

(a) Work out the length of cylinder Q.

(3 marks)

The volume of cylinder P is $100\pi \text{ cm}^3$.

(b) Work out the volume of cylinder Q.
Give your answer as a multiple of π .

(2 marks)

7.

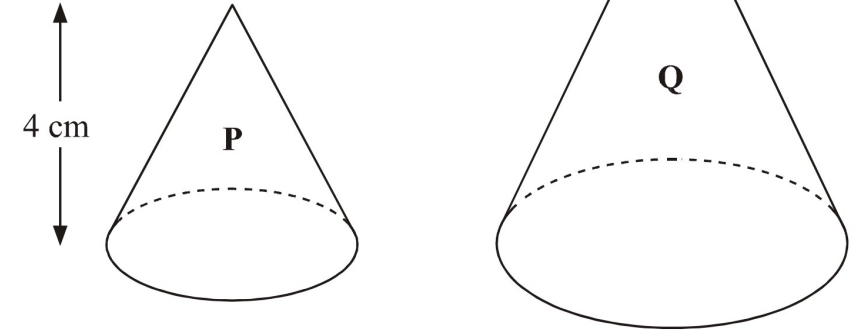

Two cones, P and Q, are mathematically similar.

The total surface area of cone P is 24 cm^2 .

The total surface area of cone Q is 96 cm^2 .

The height of cone P is 4 cm.

(a) Work out the height of cone Q.

(3 marks)

The volume of cone P is $12\pi \text{ cm}^3$.

(b) Work out the volume of cone Q.

(2 marks)

1) Equations and Indices: Easier

1) Simplify

a) $(a^5)^3$

b) $(2a)^4$

c) $(-2a^2)^4$

d) $(3a^2b^3)^3$

e) $\sqrt[3]{64t^{27}v^{15}}$

(5 Marks)

2) Express (where possible) each of the following as 2^k for some value of k

a) 8

b) 1

c) $\frac{1}{2}$

d) $\sqrt{2}$

e) $\sqrt{8}$

f) $\frac{1}{\sqrt{2}}$

g) $(\sqrt{8})^3$

(7 Marks)

1) Equations and Indices: Medium

3) Solve the equation

$$3^{x+1} = \frac{27^x}{9}$$

(5 Marks)

4) Solve the equation

$$25^{x-1} = 5\sqrt{5}$$

(5 Marks)

5) Solve the equation

$$\frac{16^x}{2^{x-1}} = 2^{\frac{1}{2}}$$

(5 Marks)

1) Equations and Indices: Harder

6) Solve the equation

$$\frac{8^{x+1}}{2^x} = 16$$

(5 Marks)

7) Solve the equation

$$27^y = 3^{1+y}$$

(5 Marks)

8) Solve the equation

$$\left(\frac{1}{4}\right)^n = 8^{n+1}$$

(5 Marks)

8.

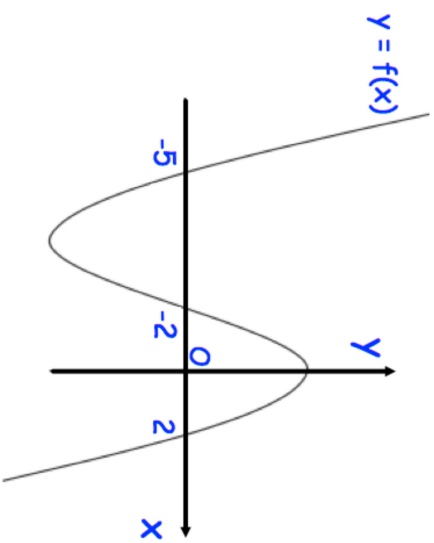

The graph of $y = f(x)$ cuts the x axis when $x = -5$, -2 and 2

Write down the coordinates of the points where these graphs cut the x axis.

(a) $y = f(-x)$

.....
(2)

(b) $y = f(x + 2)$

.....
(2)

9.

Shown below is the curve with equation $y = f(x)$.
The curve passes through the points $(-4, 0)$, $(-1, 0)$ and $(0, 5)$

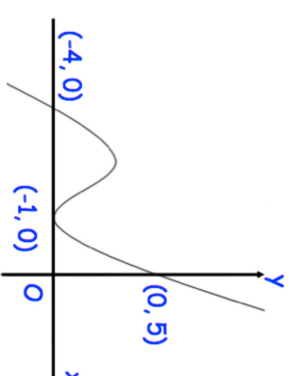

Sketch the curve with equation:

(a) $y = f(x - 1)$

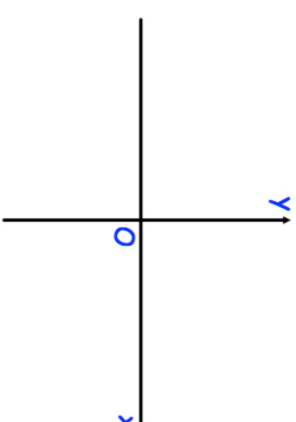

(2)

(b) $y = -f(x)$

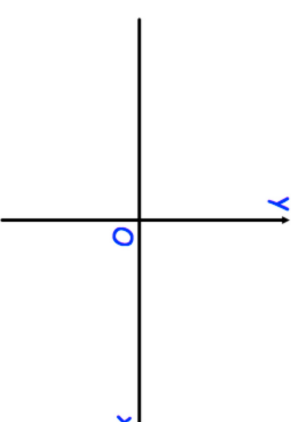

(2)

10. Shown below is a sketch of a curve with equation $y = f(x)$. The curve has a minimum point at $(-7, -4)$.

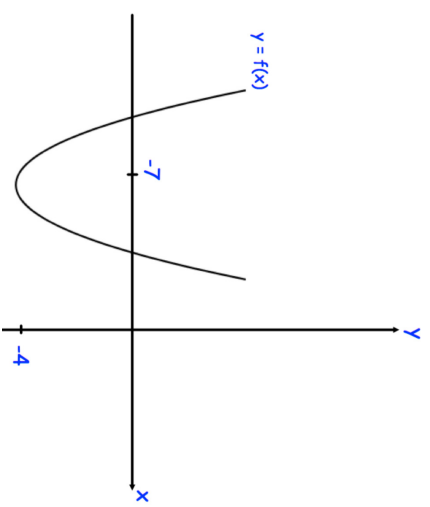

The graph of $y = f(x) + a$ has a minimum point at $(-7, 0)$, where a is a constant.

Write down the value of a .

.....
(1)

11. The graph of $y = f(x)$ is shown on the grid.

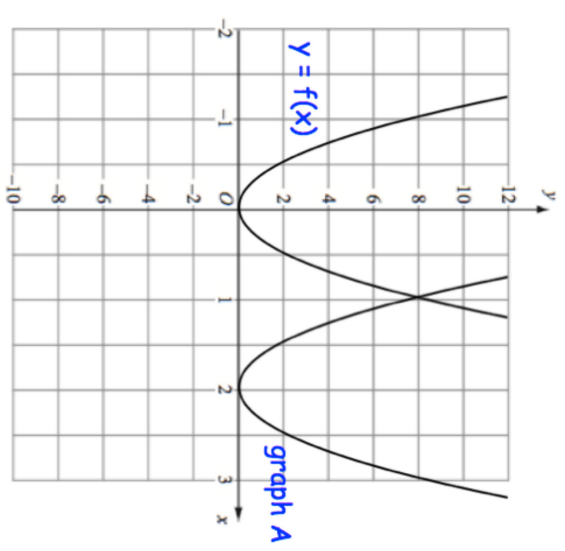

The graph A is a translation of the graph $y = f(x)$

Write down the equation of graph A.

.....
(2)

12. Shown below is the graph of $y = \cos x$

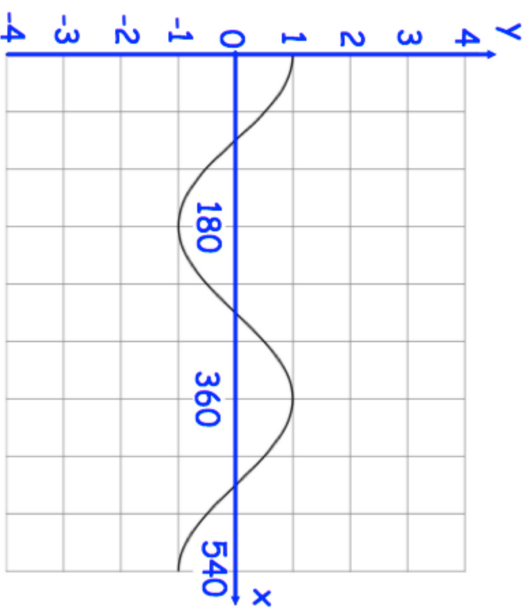

On the grid, sketch the graph of $y = 3 + \cos x$ for values of x from 0° to 540°

(2)

13. Shown below is the graph of $y = \cos x$

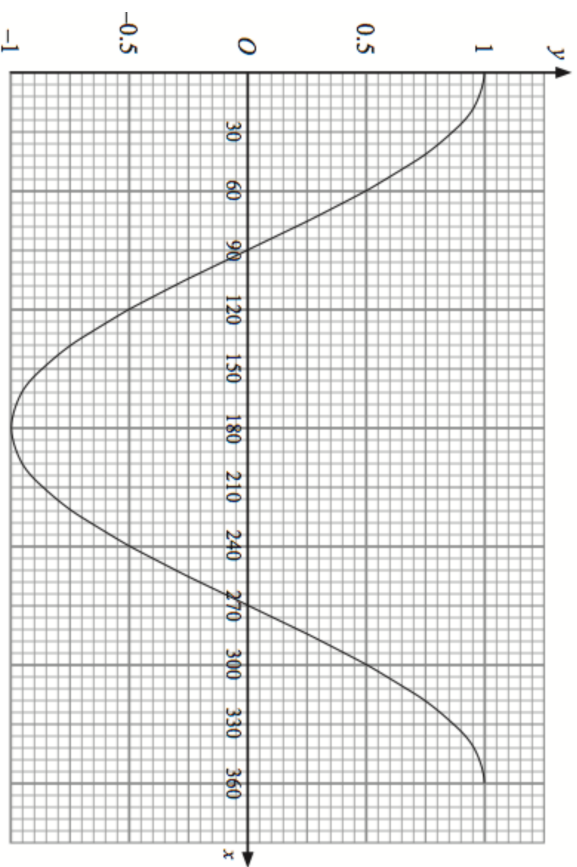

On the grid, sketch the graph of $y = \cos(x - 90^\circ)$ for values of x from 0° to 360°

(2)

14. Describe the transformation that maps the curve with equation $y = \sin(x)$ onto the curve with equation

(a) $y = -\sin(x)$

.....

.....

(2)

(b) $y = 1 + \sin(x)$

.....

(2)

(c) $y = \sin(x - 30^\circ)$

.....

(2)

15. Shown below is the graph of $y = \cos x$

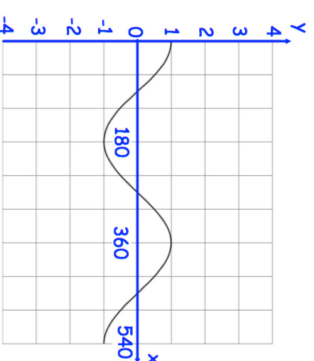

On the grid, sketch the graph of $y = 2 - \cos(x)$ for values of x from 0° to 540°

(2)

Question 5: Sketch the following graphs.

- | | | |
|--------------------------|-------------------------|------------------------|
| (a) $y = x^2 + 6x + 8$ | (b) $y = x^2 - x - 6$ | (c) $y = x^2 + 6x + 9$ |
| (d) $y = x^2 - 13x + 42$ | (e) $y = x^2 + 5x - 36$ | (f) $y = x^2 - 2x + 1$ |
| (g) $y = x^2 + 5x + 11$ | (h) $y = x^2 - 4x + 7$ | |

Question 6: Sketch the following graphs.

- | | | |
|---------------------------|--------------------------|---------------------|
| (a) $y = (x - 7)(x + 10)$ | (b) $y = (x + 3)(x + 8)$ | (c) $y = (x - 2)^2$ |
|---------------------------|--------------------------|---------------------|

Question 7: Sketch the following graphs.

- | | | |
|--------------------|-------------------|---------------------|
| (a) $y = x^2 - 49$ | (b) $y = x^2 - 1$ | (c) $y = x^2 - 196$ |
|--------------------|-------------------|---------------------|

Question 8: Michael wants to sketch the graph of $y = -x^2 + 5x + 14$

- (a) Find the value of y when $x = 0$
- (b) Use your answer to (a) to plot where the graph crosses the y -axis.
- (c) Solve the equation $-x^2 + 5x + 14 = 0$
- (d) Use your answers to (c) to help you plot where the graph crosses the x -axis.
- (e) Sketch the graph of $y = -x^2 + 5x + 14$

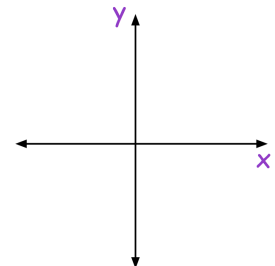

Question 9: Sketch the following graphs.

- | | | |
|--------------------------|--------------------------|-------------------------|
| (a) $y = -x^2 - 5x - 4$ | (b) $y = -x^2 + 9x - 18$ | (c) $y = 84 - 5x - x^2$ |
| (d) $y = (3 - x)(x + 8)$ | (e) $y = -x^2 - 8x - 16$ | (f) $y = 144 - x^2$ |

Question 10: Robyn wants to sketch the graph of $y = 2x^2 + 9x + 4$

- (a) Find the value of y when $x = 0$
- (b) Use your answer to (a) to plot where the graph crosses the y -axis.
- (c) Solve the equation $2x^2 + 9x + 4 = 0$
- (d) Use your answers to (c) to help you plot where the graph crosses the x -axis.
- (e) Sketch the graph of $y = 2x^2 + 9x + 4$

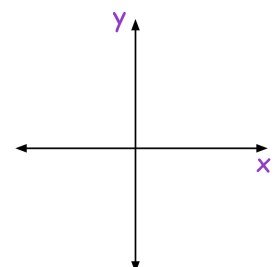

9. DEF is an equilateral triangle.

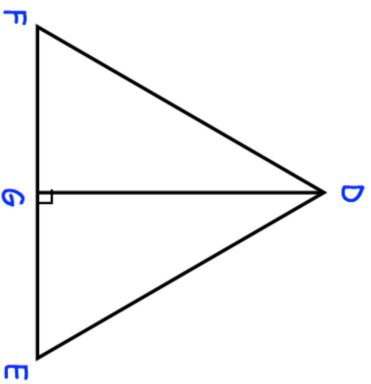

- G lies on EF.
DG is perpendicular to FE.
Prove $\triangle DFG$ is congruent to $\triangle DEG$.

(3)

10. ABC is an isosceles triangle in which $AC = BC$.
D and E are points on BC and AC such that $CE = CD$.

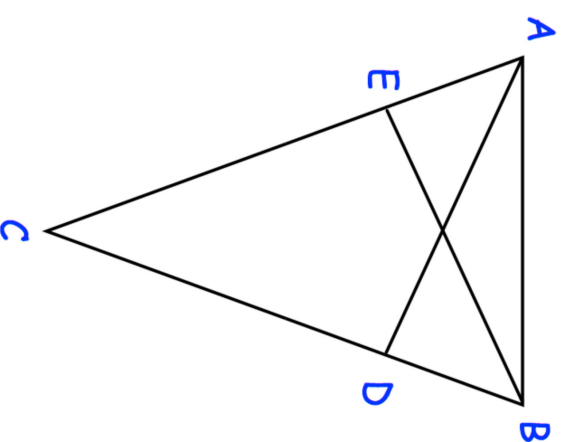

- Prove triangles ACD and BCE are congruent.

(4)

11. ABCD and LMNO are squares.
Angle CBL = x

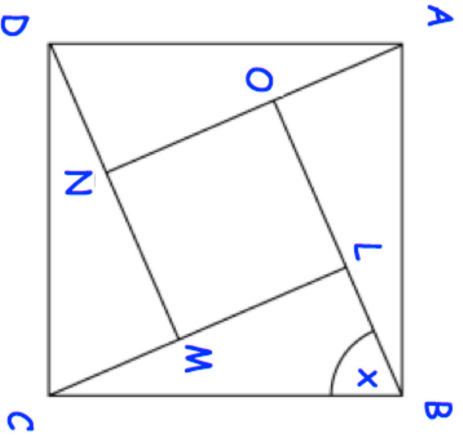

Prove that triangles ABO and CBL are congruent.

(4)

12. ABCD is a square, X is a point in the diagonal BD and the perpendicular from B to AX meets AC in Y.

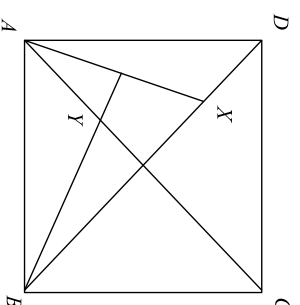

Prove that triangles AXD and AYB are congruent.

(4)

Error Intervals

Video 377 on www.corbettmaths.com

Examples



Click here



Scan here

Workout

Question 1: The mass of a coin is 8 grams to the nearest gram.
Complete the error interval for the mass of the coin

$$\dots\dots\dots \text{ g} \leq \text{mass} < \dots\dots\dots \text{ g}$$

Question 2: The distance between two cities is 900km to the nearest 100km.
Complete the error interval for the distance

$$\dots\dots\dots \text{ km} \leq \text{distance} < \dots\dots\dots \text{ km}$$

Question 3: Frank rounds a number, y , to the nearest ten.
His result is 20
Write down the error interval for y

Question 4: Lily rounds a number, y , to the nearest whole number.
Her result is 5
Write down the error interval for y

Question 5: Freya rounds a number, y , to one decimal place.
Her result is 6.4
Write down the error interval for y

Question 6: Oscar rounds a number, y , to the nearest integer.
His result is 100
Write down the error interval for y

Question 7: A number, n , is rounded to 1 decimal place.
The result is 1.3
Using inequalities, write down the error interval for n .

Question 8: A number, n , is rounded to 2 decimal places.
The result is 6.27
Using inequalities, write down the error interval for n .

Question 9: Elliott weighs 56.2kg.
This mass, m , is to the nearest 100g.
Write the error interval due to rounding.

Error Intervals

Video 377 on www.corbettmaths.com

Question 10: A number, x , is 21 when rounded to 2 significant figures.
Write down the error interval.

Question 11: A number, y , is 15000 when rounded to 2 significant figures.
Write down the error interval.

Question 12: A number, y , is 680000 when rounded to 3 significant figures.
Write down the error interval.

Question 13: The length of a line, l , was given as 2.8cm, truncated to 1 decimal place.
Complete the error interval for l

$$\dots\dots\dots \text{ cm} \leq l < \dots\dots\dots \text{ cm}$$

Question 14: A number, y , is 0.37 when truncated to 2 decimal places.
Complete the error interval for y

$$\dots\dots\dots \leq y < \dots\dots\dots$$

Question 15: A number, n , is truncated to 1 decimal place.
The result is 18.1
Using inequalities, write down the error interval for n .

Question 16: A number, n , is truncated to 3 decimal places.
The result is 4.066
Using inequalities, write down the error interval for n .

Apply

Question 1: The length of each side of a regular hexagon is 4.7cm to 1 decimal place.
Write the error interval for the perimeter, P

Question 2: Grace and George complete a crossword.
It takes Grace 9 minutes to complete the crossword to the nearest minute.
It takes George 11 minutes to complete the crossword to the nearest minute.

Show that the total time for both people to complete the crossword could be 20 minutes 50 seconds.

Question 3: A man jogs 200 metres to the nearest 10 metres.
It takes him 30 seconds to the nearest 10 seconds.

Work out the error interval for his speed, s .



Error Intervals

Video 377 on www.corbettmaths.com

Question 4: A number, x , is 1.92 when truncated to 2 decimal places.
Matthew has been asked to write down the error interval.
This is his answer.

$$1.915 \leq x < 1.925$$

Explain why Matthew is wrong.

Question 5: A number, n , is rounded to 3 significant figures.
The result is 7500
Norris has been asked to write down the error interval for n .
This is his answer.

$$7450 < x < 7550$$

Explain why Norris is wrong.

Answers

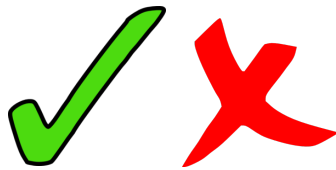

Click here



Scan here

Box Plots

Videos 149 and 150 on www.corbettmaths.com

Question 4: Draw a box plot for each set of data

- (a) 8, 10, 13, 14, 14, 15, 15, 16, 18, 19, 21, 22, 24, 29, 35
- (b) 40, 80, 90, 90, 100, 120, 130
- (c) 5.9, 7.3, 7.8, 8, 8.4, 8.7, 8.9, 8.9, 8.9, 9, 9, 9.1, 9.1, 9.3, 9.5, 9.6, 9.9, 10.5, 10.9

Question 5: Compare the distributions of each pair of box plots below.

(a)

7A results

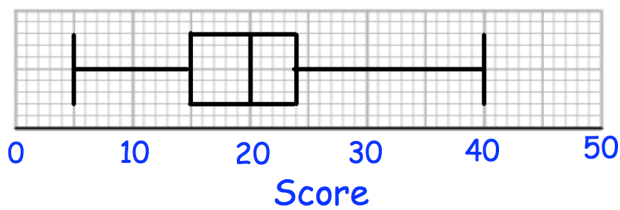

(b)

Time taken to complete puzzle - Children

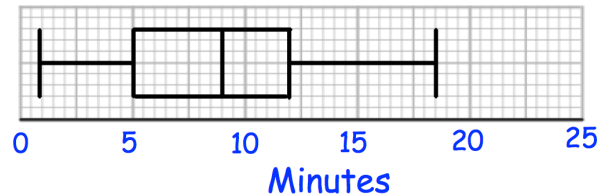

7B results

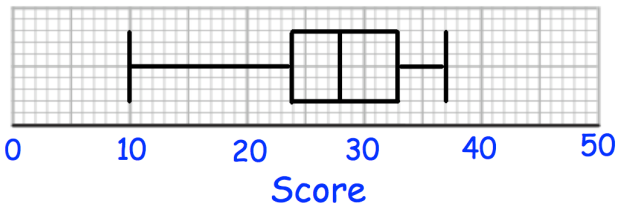

Time taken to complete puzzle - Adults

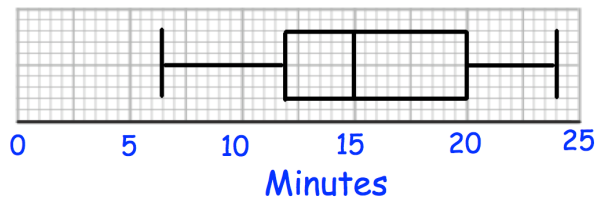

(c)

Length of red squirrels

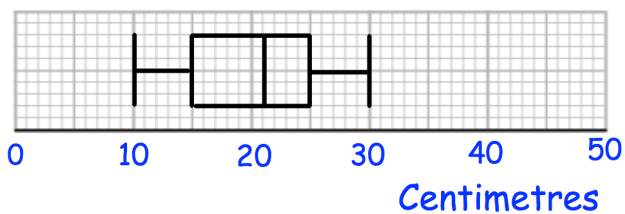

(d)

Reaction Times - Group A

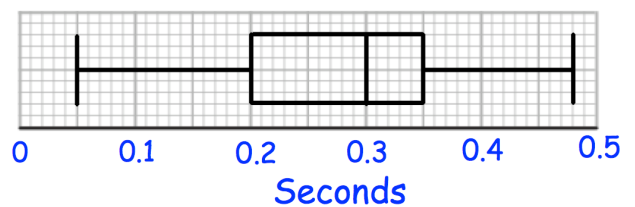

Length of grey squirrels

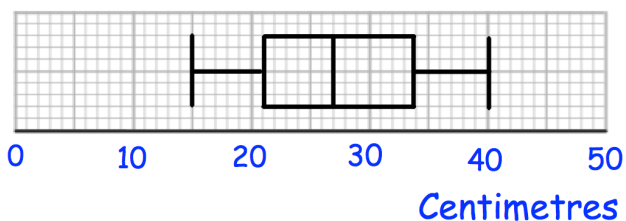

Reaction Times - Group B

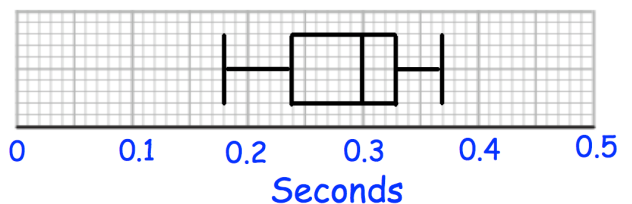

Box Plots

Videos 149 and 150 on www.corbettmaths.com

Question 3: Mr Jones is an estate agent on the Isle of Man. He has created this table to show information about the prices of houses he has sold. Explain how you know he has made a mistake.

Median	£375,000
Range	£235,000
Interquartile Range	£590,000

Question 4: The box plot show information about the masses of apples in a crate.

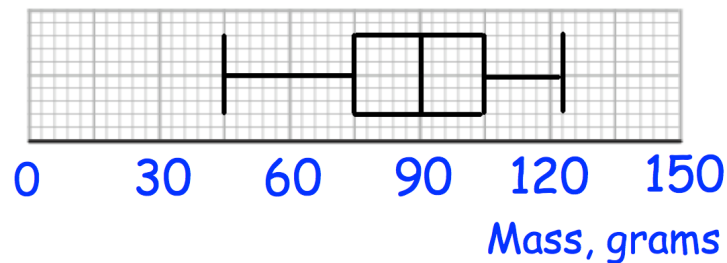

Jack is going to select apples at random from the crate. After selecting each apple, he records its mass and returns it to the crate before picking another. Work out the probability that:

- Jack picks two apples, both under 75g
- Jack picks two apples, both over 90g
- Jack picks two apples, both over 105g
- Jack picks two apples, one under 90g and one over 105g
- Jack picks three apples, all over 105g
- Jack picks three apples, two over 105g and one under 75g.

Answers



Click here



Scan here

Question 2:  The value of a motorcycle was £14000 on 1st April 2014.
Every three months the value of the motorcycle decreases by 2% of its value at the start of that three months.
What was the value of the motorcycle on 1st April 2016?

Question 3:  When a ball is dropped, it bounces and then rises.
The ball rises to 90% of the height from which it is dropped.
The ball is dropped from a height of 4m.



- (a) Calculate the height of the rise after the first bounce.
- (b) Calculate the height of the rise after the second bounce.

The ball carries on bouncing, each time rising to 90% of the last rise.
(c) For how many bounces does it rise to height greater than 1m?

Question 4:  The population of a country is increasing by 5% a year.
How many years will it take the population of the country to double?

Question 5:  Raheem and Ben invest money in 2010.
Raheem invests £1000 at Banks'R'us, who pay 3% interest per year.
Ben invests £1400 at Bank World, who pay 1% interest per year
In which year will Raheem's investment be worth more than Ben's?

Question 6:  The population of a country increases by $x\%$ each year.
In 2014 the population of the country was 24,000,000.
Three years later, the population was 26,996,736.
Find x .

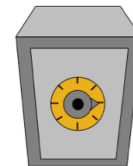

Question 7:  Charlotte invests £5000.
The bank pays 10% interest for the first year and then $y\%$ every year after that.
After three years, Charlotte has £5610.55
Calculate y .

Answers



Click here



Scan here

Product Rule for Counting

Video 383 on www.corbettmaths.com

- Question 6: Oliver picks a 4-digit **even** number that is greater than 3000.
The second digit is a multiple of 4.
How many different numbers could Oliver pick?
- Question 7: Sophia is creating a 6-digit code to lock her iPad.
She only uses digits greater than 2.
She only uses each digit once.
How many possible codes can Sophia create?
- Question 8: In a class, there are 10 boys and 9 girls.
The teacher has been asked to pick one boy and one girl to win a prize.
How many possible pairs of students can the teacher pick?
- Question 9: Jason picks a 5-digit number that is less than 80000.
The first digit is odd.
The fourth and fifth digits are equal.
How many different numbers can Jason pick?
- Question 10: A headteacher wants to survey two Year 7 students.
There are 100 students in Year 7.
How many possible pairs of students can the headteacher pick?
- Question 11: How many even numbers greater than 40000 can be created using these digits?

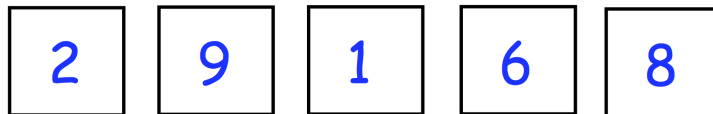

Apply

- Question 1: On a school trip, students are given a packed lunch.
The students can choose one piece of fruit and one snack.
There are 8 different pieces of fruit and some different snacks.
Altogether there are 104 different ways to choose one piece of fruit and one snack
How many different snacks are there?

Product Rule for Counting

Video 383 on www.corbettmaths.com

Question 2: At a summer camp, children pick a morning, an afternoon and an evening activity.

There are 4 morning and 7 evening activities to pick from.

Altogether there are 224 different ways to choose their activities.

How many afternoon activities are there?

Question 3: In a gym there are

12 exercise classes on a Monday

13 exercise classes on a Wednesday

7 exercise classes on a Friday

Katie is going to attend either

- or a class on Monday and a class on Friday
- or a class on Wednesday and a class on Friday
- or a class on Monday, Wednesday and Friday

Work out how many different ways there are to pick which exercises classes Katie is going to attend.

Question 4: A group of 10 people enter a room.
Each person shakes hands, once, with all the other people in the room.

How many handshakes are there in total?



Question 5: A pizza parlour sells 9 different toppings.

Michael orders a pizza with 2 different toppings.

(a) How many different pizzas can he choose from?

Beth orders a pizza with 3 different toppings.

(b) How many different pizzas can she choose from?

John orders a pizza with 4 different toppings.

(c) How many different pizzas can he choose from?

Answers



Click here



14.

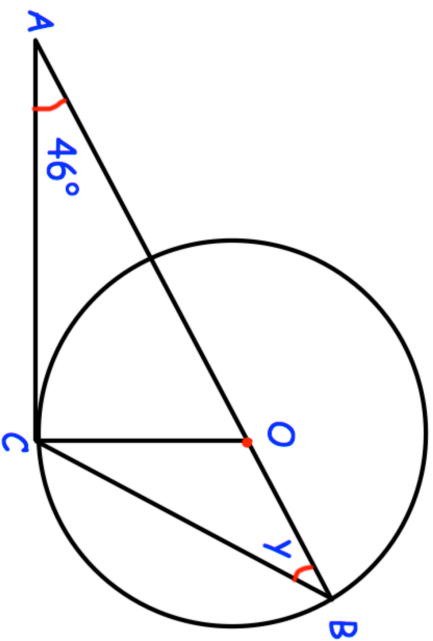

AOB is a straight line.

B and C are points on the circumference of a circle, centre O .

AC is a tangent to the circle.

Work out the size of the angle y .

.....
(4)

15.

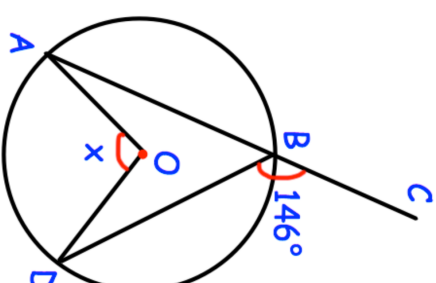

Shown is a circle with centre O .

ABC is a straight line.

Angle CBD is 146°

Find the size of angle AOD .

.....
(3)

16. RS is a tangent to the circle at R.

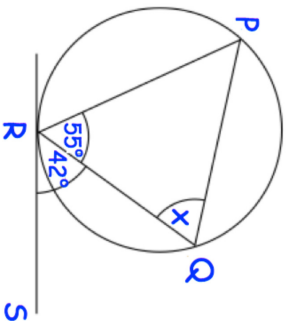

Calculate the value of x .

Give reasons for your answer.

.....°
(3)

17. AC and BC are tangents to the circle with centre O.

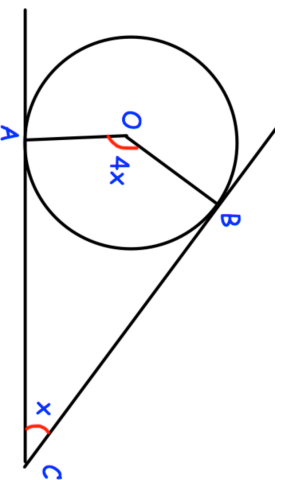

Find the size of x .

.....°
(3)

18. A, B and C are points on the circumference of a circle with centre O.

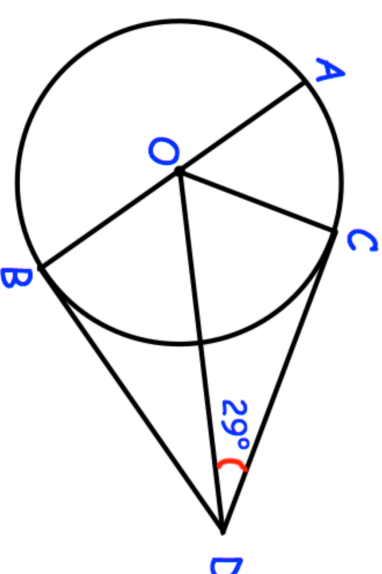

AOB is a diameter of the circle.

CD and BD are tangents to the circle.

Angle CDO = 29°

Work out the size of angle AOC.

Give reasons for each stage of your working.

.....°
(4)

19. DEFG is a cyclic quadrilateral.
 PDQ is a tangent at D.
 O is the centre of the circle.
 DEF is an isosceles triangle.

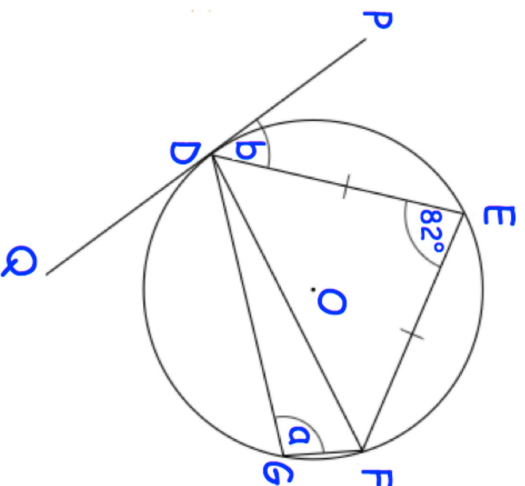

- (a) Work out the value of a.
 (b) Work out the value of b.
 (c) Write down the name of the circle theorem used in part (b)

.....° (2)
° (3)
 (1)

- 20.

Shown is a circle, centre O.
 B, C and D are points on the circumference.

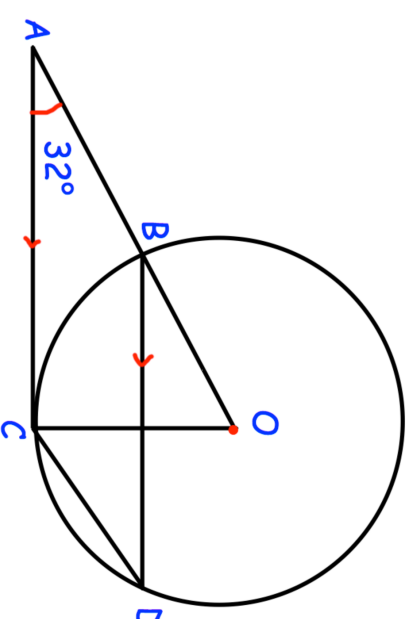

ABO is a straight line.
 AC is a tangent to the circle.

- (a) Work out angle AOC.
 (b) Work out angle BDC.
 (c) Work out angle ACD.

.....° (2)
° (3)
° (1)

21. PQRS is a cyclic quadrilateral.
 APB is a tangent to the circle at P.
 PQ is parallel to SR.
 Angle SPB = 35° and angle PSQ = 80°

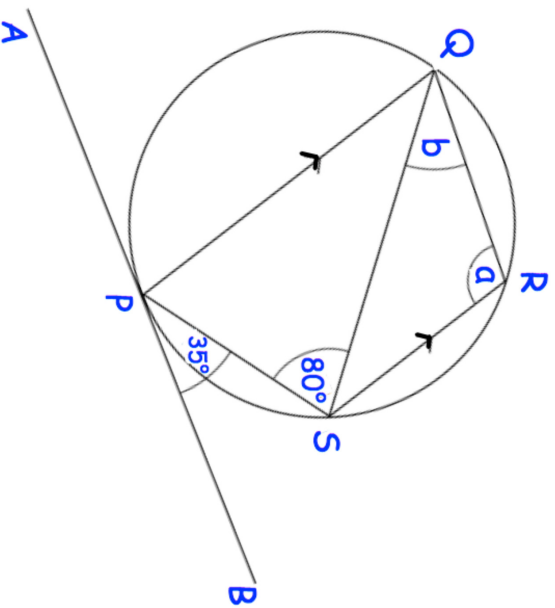

- (a) Work out the size of angle QRS.
- (b) Work out the size of angle ROS.

.....^o
(4)

.....^o
(2)

- 22.

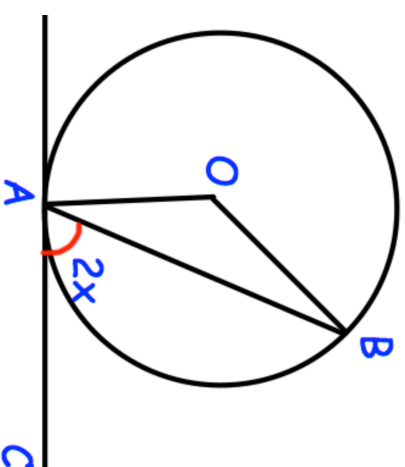

- A and B are points on the circumference of a circle, centre O.
 CA is a tangent to the circle.
 Angle CAB = $2x$
- Prove that angle AOB = $4x$
 Give reasons for each stage of your working.

(4)

1.

[4 marks]

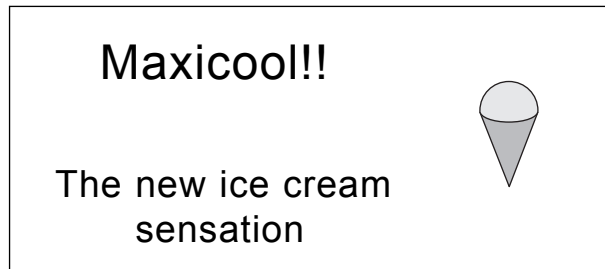

A Maxicool consists of a cone full of ice cream with a hemisphere of ice cream on top.
The radius of the hemisphere is 3 cm.
The radius of the base of the cone is 3 cm.
The height of the cone is 10 cm.

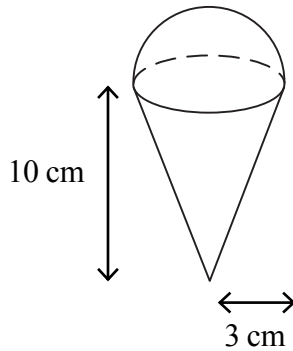

Diagram **NOT** accurately drawn

Calculate the total volume of ice cream in a Maxicool.
Give your answer correct to 3 significant figures.

2.

[5 marks]

A solid is made from a cylinder and a hemisphere.
The cylinder has radius 1.5 cm and height 4 cm.
The hemisphere has radius 1.5 cm.

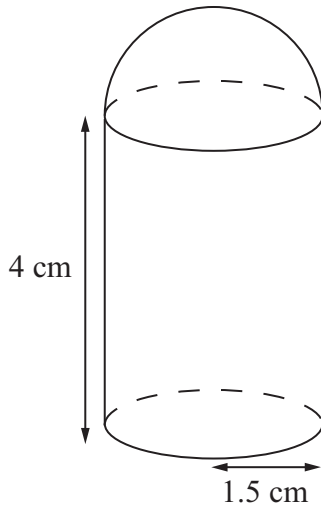

Diagram **NOT**
accurately drawn

Work out the total volume of the solid.
Give your answer correct to 3 significant figures.

..... cm³

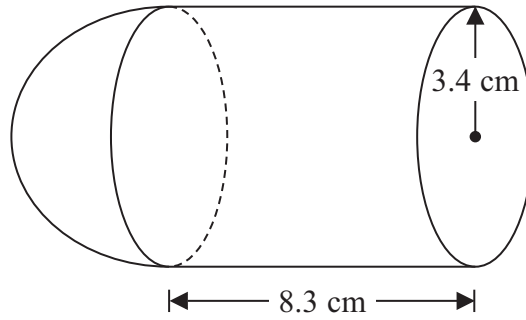

Diagram **NOT**
accurately drawn

The diagram shows a shape made from a solid cylinder and a solid hemisphere.
The cylinder has a radius of 3.4 cm and a length of 8.3 cm.
The hemisphere has a radius of 3.4 cm.

Calculate the total surface area of the solid shape.
Give your answer correct to 3 significant figures.

..... cm²

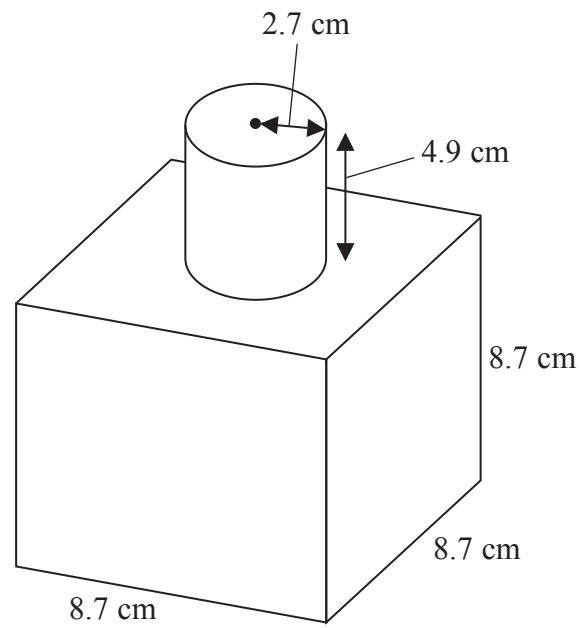

Diagram **NOT**
accurately drawn

The diagram shows a shape made from a solid cube and a solid cylinder.
The cube has sides of length 8.7 cm.
The cylinder has a radius of 2.7 cm and a height of 4.9 cm.

Calculate the total surface area of the solid shape.
Give your answer correct to 3 significant figures.

..... cm²

The diagram shows a sphere and a cone.

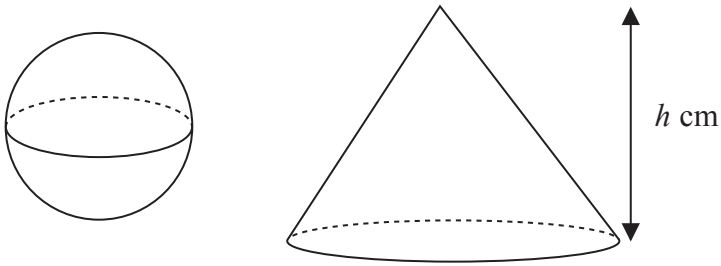

Diagram **NOT**
accurately drawn

The cone has height h cm.

The radius of the base of the cone is 3 times the radius of the sphere.

Given that the volume of the sphere is equal to the volume of the cone,
find an expression for the radius of the sphere in terms of h .

Give your expression in its simplest form.

The diagram shows two solid shapes, shape **A** and shape **B**.

Shape **A** is made of a hemisphere and a cone.

Shape **B** is a cylinder.

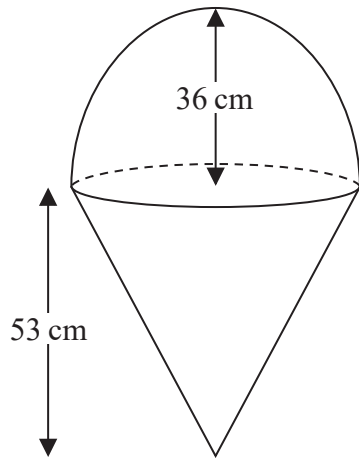

A

Diagram **NOT**
accurately drawn

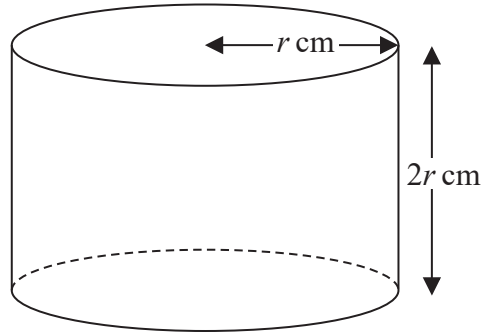

B

For shape **A**

radius of the hemisphere is 36 cm
radius of the base of the cone is 36 cm
height of the cone is 53 cm

For shape **B**

radius of the cylinder is r cm
height of the cylinder is $2r$ cm

The volume of shape **A** = the volume of shape **B**

Calculate the height of shape **B**.

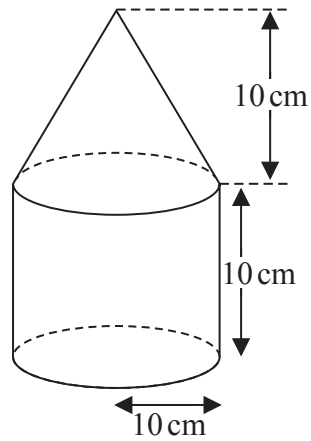

Diagram **NOT**
accurately drawn

The diagram shows a solid shape made from a cone on top of a cylinder.

The cone has a radius of 10 cm and a height of 10 cm.

The cylinder has a radius of 10 cm and a height of 10 cm.

The centre of the base of the cone coincides with the centre of the top face of the cylinder.

The total surface area of the solid is $A \text{ cm}^2$

Show that $A = (300 + 100\sqrt{2})\pi$

The diagram shows a cylinder and a sphere.

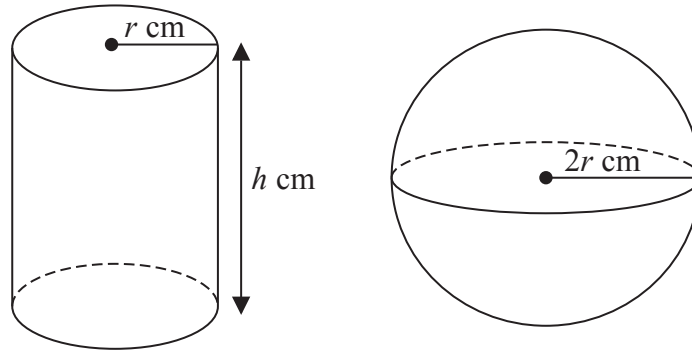

Diagram **NOT**
accurately drawn

The cylinder has radius r cm and height h cm.

The sphere has radius $2r$ cm.

The volume of the cylinder is equal to the volume of the sphere.

Find an expression for h in terms of r .

Give your answer in its simplest form.

.....

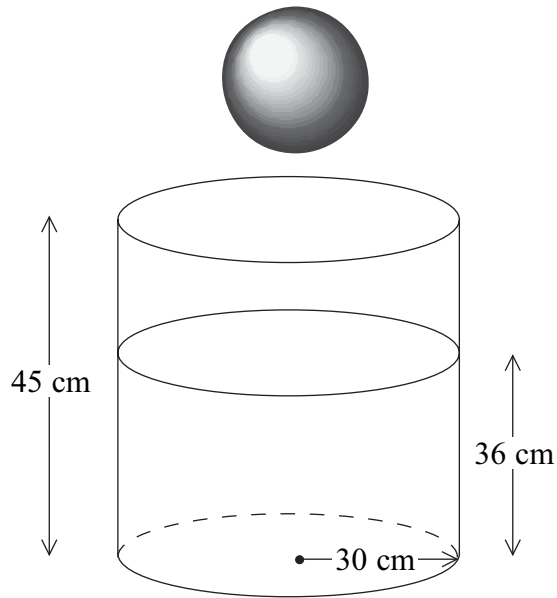

Diagram **NOT**
accurately drawn

A cylindrical tank has a radius of 30 cm and a height of 45 cm.
The tank contains water to a depth of 36 cm.

A metal sphere is dropped into the water and is completely covered.
The water level rises by 5 cm.

Calculate the radius of the sphere.

..... cm

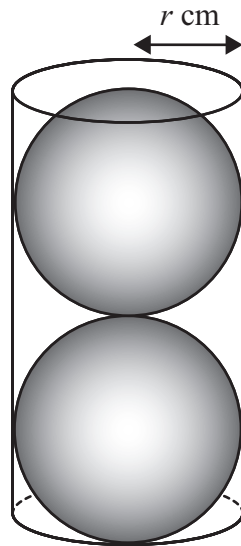

Diagram **NOT**
accurately drawn

Two solid spheres, each of radius r cm, fit exactly inside a hollow cylinder.

The radius of the cylinder is r cm.

The height of the cylinder is equal to $4r$ cm.

The volume of the space inside the cylinder, not occupied by the spheres, is $\frac{125}{6}\pi$ cm³

Calculate the value of r .

Show your working clearly.

$r = \dots\dots\dots$

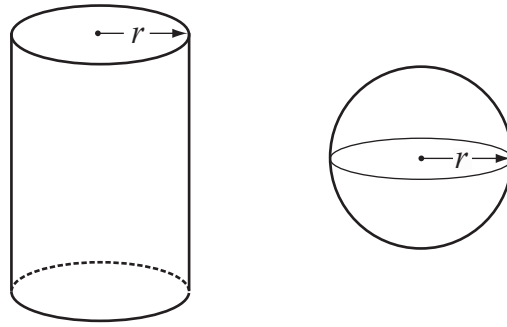

Diagram **NOT**
accurately drawn

The diagram shows a solid cylinder and a solid sphere.
The cylinder has radius r .
The sphere has radius r .

Given that $\frac{\text{Total surface area of cylinder}}{\text{Surface area of sphere}} = 2$

find the value of $\frac{\text{Volume of cylinder}}{\text{Volume of sphere}}$

.....

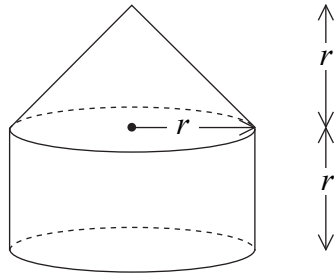

The diagram shows a solid made from a cone and a cylinder.

The cylinder has radius r and height r .

The cone has base radius r and height r .

- (a) Show that the total volume of the solid is equal to the volume of a sphere of radius r .

(2)

The curved surface area of a cylinder with base radius r and height h is $2\pi rh$.

The curved surface area of a cone with base radius r and slant height l is πrl .

- (b) Show that the **total** surface area of the above solid is greater than the surface area of a sphere of radius r .

(3)

Applying Limits of Accuracy

Video 184 on www.corbettmaths.com

Question 8: A rectangular football pitch has a width of 72m, measured to the nearest metre. The length of the pitch is 105m, measured to the nearest 5 metres.

Work out the lower bound for the perimeter of the pitch.

Question 9: The lengths of time taken for 4 people to complete a puzzle are listed below. Each time is given to one decimal place.

20.8 seconds 35.1 seconds 19.7 seconds 41.3 seconds

- (a) Work out the greatest possible range
(b) Work out the smallest possible mean.

Question 10: Mr Rodgers wants to keep 28 new maths textbooks on a shelf in his classroom. Each book has a mass of 700g correct to 1 significant figure. The shelf can hold up to 20kg to the nearest kilogram. Can the shelf safely hold the textbooks?

Question 11: The base of a triangle is 30cm, correct to 2 significant figures. The height of the triangle is 40cm, correct to 1 significant figure. Calculate the upper bound for the area of the triangle

Question 12: Kelly drove a distance of 120 miles, to the nearest 10 miles, in a time of 2 hours, to the nearest hour. Work out the difference between Kelly's greatest possible and lowest possible average speed.

Question 13: Rosie is buying strawberries, apples and grapes for a picnic. She buys 4kg of strawberries and 3kg of grapes, both to the nearest kilogram. Rosie buys 50 apples to the nearest 10 apples. A kilogram of strawberries costs £1.20 to the nearest 10p. A kilogram of grapes costs £1.30 to the nearest 10p. An apple costs 20p each to the nearest 10p. Work out the upper bound for the amount of money Rosie would have to pay

Question 14: A circle has an area of 600cm^2 to 2 significant figures. Work out the lower bound of the radius.

Question 15: $w = aT$
Given $a = 15$ correct to 2 significant figures
and $w = 700$ correct to 2 significant figures
Calculate the upper bound for T

Applying Limits of Accuracy

Video 184 on www.corbettmaths.com

Question 16: Shane estimated the distance between Cardiff and Swansea is 40 miles and that his average driving speed would be 60 mph.

He estimated the distance to the nearest 5 miles and the speed to the nearest 10mph.

Calculate the upper bound for the time the journey should take.
Give your answer to the nearest minute.

Question 17: A solid metal sphere has a radius of 4cm to 1 significant figure.
The sphere has a mass of 1200g to 2 significant figures.

Work out the lower bound for the density of the metal.

Question 18: The final velocity of a traveling object is given by the formula, $v = u + at$

where v is the final velocity
 u is the initial velocity
 a is the acceleration
and t is the time.

Given $u = 5.4\text{m/s}$ correct to 1 decimal place
 $a = 4.9\text{m/s}^2$ correct to 1 decimal place
 $v = 25.32$ correct to 2 decimal places

Calculate the upper bound for t .

Question 19: The population of a country is 6.4×10^6 to the nearest hundred thousand

The area of country is $8.4 \times 10^4 \text{ km}^2$ to the nearest 100km^2

Calculate the lower bound of the population density.

Answers



Click here



Scan here

C1 COORDINATE GEOMETRY

Worksheet A

- Find the gradient of the line segment joining each pair of points.
 - (3, 1) and (5, 5)
 - (4, 7) and (10, 9)
 - (6, 1) and (2, 5)
 - (-2, 2) and (2, 8)
 - (1, 3) and (7, -1)
 - (4, 5) and (-5, -7)
 - (-2, 0) and (0, -8)
 - (8, 6) and (-7, -2)
- Write down the gradient and y-intercept of each line.
 - $y = 4x - 1$
 - $y = \frac{1}{3}x + 3$
 - $y = 6 - x$
 - $y = -2x - \frac{3}{5}$
- Find the gradient and y-intercept of each line.
 - $x + y + 3 = 0$
 - $x - 2y - 6 = 0$
 - $3x + 3y - 2 = 0$
 - $4x - 5y + 1 = 0$
- Write down, in the form $y - y_1 = m(x - x_1)$, the equation of the straight line with the given gradient which passes through the given point.
 - gradient 2, point (4, 1)
 - gradient 5, point (2, -5)
 - gradient -3, point (-1, 1)
 - gradient $\frac{1}{2}$, point (1, 6)
 - gradient -2, point $(\frac{3}{4}, -\frac{1}{4})$
 - gradient $-\frac{1}{5}$, point (-3, -7)
- Find, in the form $y = mx + c$, the equation of the straight line with the given gradient which passes through the given point.
 - gradient 3, point (1, 2)
 - gradient -1, point (5, 3)
 - gradient 4, point (-2, -3)
 - gradient -2, point (-4, 1)
 - gradient $\frac{1}{3}$, point (-3, 1)
 - gradient $-\frac{5}{6}$, point (9, -2)
- Find, in each case, the equation of the straight line with gradient m which passes through the point P . Give your answers in the form $ax + by + c = 0$, where a , b and c are integers.
 - $m = 1$, $P(2, -4)$
 - $m = \frac{1}{2}$, $P(6, 1)$
 - $m = -4$, $P(-1, 8)$
 - $m = \frac{2}{5}$, $P(-3, 5)$
 - $m = -3$, $P(\frac{3}{2}, -\frac{1}{8})$
 - $m = -\frac{3}{4}$, $P(\frac{2}{3}, -7)$
- Find, in the form $y = mx + c$, the equation of the straight line passing through each pair of points.
 - (0, 1) and (4, 13)
 - (2, 9) and (7, -1)
 - (-4, 3) and (2, 7)
 - $(-\frac{1}{2}, -2)$ and (2, 8)
 - (3, -2) and (18, -5)
 - (-3.2, 4) and (-2, 0.4)
- Find, in the form $ax + by + c = 0$, where a , b and c are integers, the equation of the straight line which passes through each pair of points.
 - (3, 0) and (5, 2)
 - (-1, 8) and (5, -4)
 - (-5, 3) and (7, 5)
 - (-4, -1) and (8, -17)
 - (2, -1.5) and (7, 0)
 - $(-\frac{3}{5}, \frac{1}{10})$ and (3, 1)
- The straight line l passes through the points $A(-6, 8)$ and $B(3, 2)$.
 - Find an equation of the line l .
 - Show that the point $C(9, -2)$ lies on l .
- The point $M(k, 2k)$ lies on the line with equation $x - 3y + 15 = 0$. Find the value of the constant k .

C1 COORDINATE GEOMETRY

Worksheet C

- 1 The straight line l has gradient -3 and passes through the point with coordinates $(3, -5)$.
- a Find an equation of the line l .
- The straight line m passes through the points with coordinates $(-1, -2)$ and $(4, 1)$.
- b Find the equation of m in the form $ax + by + c = 0$, where a, b and c are integers.
- The lines l and m intersect at the point P .
- c Find the coordinates of P .
- 2 Given that the straight line passing through the points $A(2, -3)$ and $B(7, k)$ has gradient $\frac{3}{2}$,
- a find the value of k ,
- b show that the perpendicular bisector of AB has the equation $8x + 12y - 45 = 0$.
- 3 The vertices of a triangle are the points $A(5, 4)$, $B(-5, 8)$ and $C(1, 11)$.
- a Find the equation of the straight line passing through A and B , giving your answer in the form $ax + by + c = 0$, where a, b and c are integers.
- b Find the coordinates of the point M , the mid-point of AC .
- c Show that OM is perpendicular to AB , where O is the origin.

4

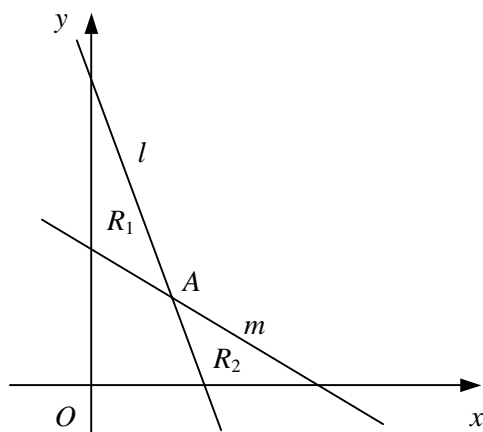

The line l with equation $3x + y - 9 = 0$ intersects the line m with equation $2x + 3y - 12 = 0$ at the point A as shown in the diagram above.

- a Find, as exact fractions, the coordinates of the point A .
- The region R_1 is bounded by l , m and the y -axis.
- The region R_2 is bounded by l , m and the x -axis.
- b Show that the ratio of the area of R_1 to the area of R_2 is $25 : 18$.
- 5 The straight line l has the equation $2x + 5y + 10 = 0$.
- The straight line m has the equation $6x - 5y - 30 = 0$.
- a Sketch the lines l and m on the same set of axes showing the coordinates of any points at which each line crosses the coordinate axes.
- The points where line m crosses the coordinate axes are denoted by A and B .
- b Show that l passes through the mid-point of AB .

Apply

Question 1: ABC is a triangle.

Describe fully a **single** transformation of ABC so that:

- (a) None of the vertices are invariant.
- (b) Exactly one vertex is invariant.
- (c) Exactly two vertices are invariant.

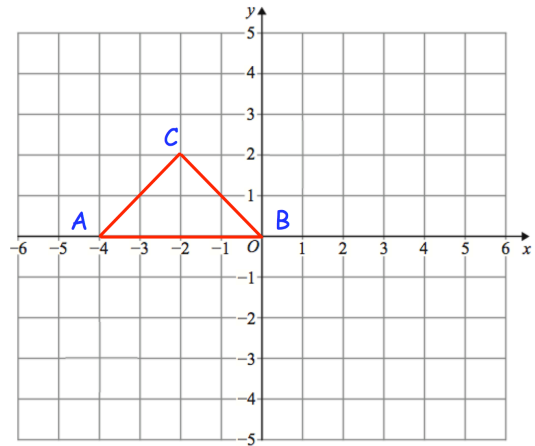

Question 2: Here is triangle ABC

Olivia says "if ABC is reflected in the line $x = -3$ there is one invariant point."

Amelia says "if ABC is reflected in the line $y = -2$ there are two invariant points."

Isla says "if ABC is reflected in the line $x = 1$ there are two vertices that are invariant."

Which student is incorrect? Explain your answer.

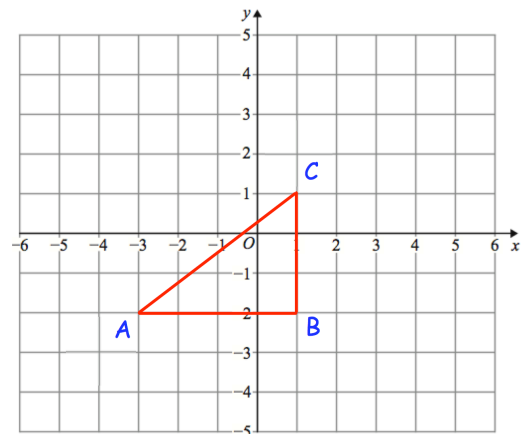

Question 3: Here is a sketch of triangle ABC.

Describe fully a **single** transformation of ABC so that all the points on AC are invariant and the point B is not invariant.

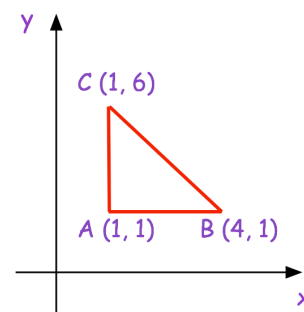

Question 4: Here is shape ABCDEF

Describe fully **single** transformations so that from the six vertices:

- (a) only vertices B and C are invariant.
- (b) only vertex F is invariant.
- (c) only vertices B, D and F are invariant.

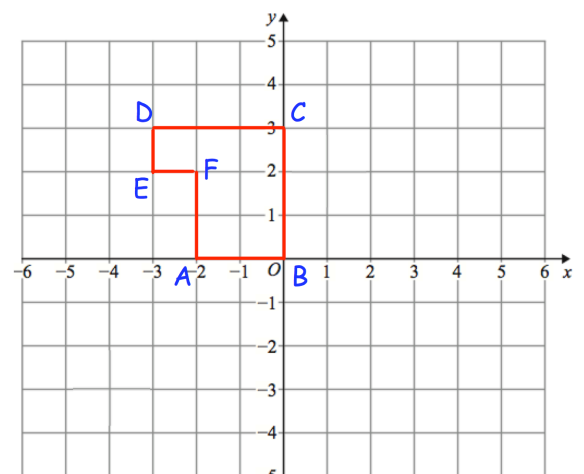

Invariant Points

Video 392 on www.corbettmaths.com

Question 5: Here is quadrilateral ABCD

ABCD is reflected in the line $x = -1$
 followed by a reflection in the line $y = -x$
 followed by a rotation of 180° about $(-1, -1)$

Which of the vertices are invariant?

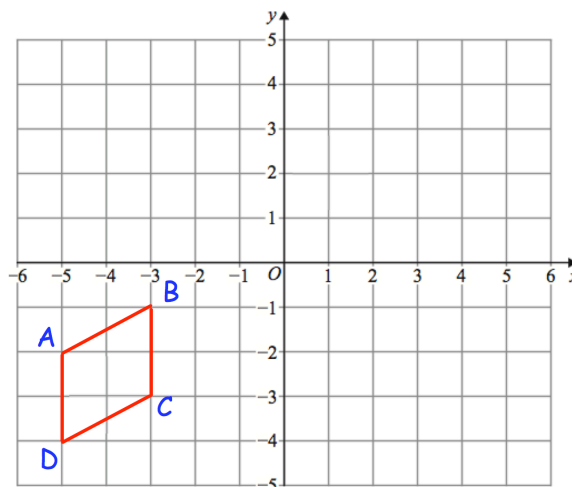

Question 6: Shown is triangle ABC

ABC is rotated 180° about $(-1, 2)$ and then
 translated by the vector $\begin{pmatrix} 2 \\ -4 \end{pmatrix}$

Write down the coordinate of the invariant point.

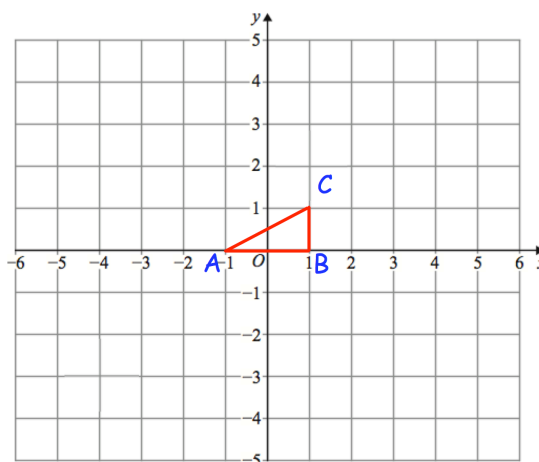

Answers



Click here



Scan here

'S

**GCSE MATHEMATICS
REVISION PACK**