

Ratio problem solving for the new GCSE

- 1) I have 3 types of shapes: triangle, square or circle in the ratio 3:6:1. The triangles are either red or blue. The ratio of red triangles to blue triangles is 4:5. Given that I have 12 red triangles, how many circles are there?
- 2) In my house, the ratio of dogs to fish is 1:10. The ratio of fish to cats is 6:1. What is the ratio of dogs to cats?
- 3) The ratio of rabbits to guinea pigs in a shop is 2:7. The ratio of brown rabbits to grey rabbits is 2:3. What fraction of the animals in the shop are grey rabbits?
- 4) The ratio of daisies to fuchsias in my garden is 2:3. The ratio of fuchsias to roses is 10:3. What is the ratio of daisies to fuchsias to roses?
- 5) I am choosing shapes out of a bag. The ratio of blue shapes to red shapes are 2:1. For the blue shapes, the ratio of spheres to cubes is 2:3. For the red shapes, the ratio of the spheres to cubes is 1:4. Given that there are 12 red spheres, how many blue cubes are there?
- 6) In a school, 55% of the pupils are girls. Out of the girls, the ratio of ones with blonde hair to ones with brown hair is 2:3. What percentages of pupils are blonde girls?
- 7) The ratio of lipsticks to eye shadow in my makeup bag is 1:9. The ratio of eye shadow to mascara is 3:2. Given that I have 3 more eye shadows than mascaras, how many lipsticks do I have?
- 8) I have a box of chocolates with white, milk and dark chocolate in. The ratio of White to Not White is 3:4. The Ratio of Not dark to dark is 17:4. What is the ratio of White: Milk : Dark?
- 9) I am on a farm with pigs and horses. The ratio of pigs to horses is 4:1. The ratio of adult pigs to piglets is 1:5. The ratio of adult horse to foal is 3:1. What fraction of the farm are babies (foals and piglets)?
- 10) On a table there are some sandwiches. The ratio of sandwiches with white bread to brown bread is 10:3. Out of the sandwiches that are white, $\frac{2}{3}$ are vegetarian. Out of the sandwiches that are on brown bread, half are vegetarian. What fraction of the sandwiches are vegetarian?
- 11) The ages of Adam, Ben and Caleb are in the ratio 5:7:11. Next year, they will be in the ratio 8:11:17. How old are they all now?

Ratio problem solving for the new GCSE **answers**

- 1) I have 3 types of shapes: triangle, square or circle in the ratio 3:6:1. The triangles are either red or blue. The ratio of red triangles to blue triangles is 4:5. Given that I have 12 red triangles, how many circles are there? **9 circles**
- 2) In my house, the ratio of dogs to fish is 1:10. The ratio of fish to cats is 6:1. What is the ratio of dogs to cats? **3:5**
- 3) The ratio of rabbits to guinea pigs in a shop is 2:7. The ratio of brown rabbits to grey rabbits is 2:3. What fraction of the animals in the shop are grey rabbits? **$\frac{2}{15}$**
- 4) The ratio of daisies to fuchsias in my garden is 2:3. The ratio of fuchsias to roses is 10:3. What is the ratio of daisies to fuchsias to roses? **20:9**
- 5) I am choosing shapes out of a bag. The ratio of blue shapes to red shapes are 2:1. For the blue shapes, the ratio of spheres to cubes is 2:3. For the red shapes, the ratio of the spheres to cubes is 1:4. Given that there are 12 red spheres, how many blue cubes are there? **72**
- 6) In a school, 55% of the pupils are girls. Out of the girls, the ratio of ones with blonde hair to ones with brown hair is 2:3. What percentages of pupils are blonde girls? **22%**
- 7) The ratio of lipsticks to eye shadow in my makeup bag is 1:9. The ratio of eye shadow to mascara is 3:2. Given that I have 3 more eye shadows than mascaras, how many lipsticks do I have? **1**
- 8) I have a box of chocolates with white, milk and dark chocolate in. The ratio of White to Not White is 3:4. The Ratio of Not dark to dark is 17:4. What is the ratio of White: Milk : Dark? **9:8:4**
- 9) I am on a farm with pigs and horses. The ratio of pigs to horses is 4:1. The ratio of adult pigs to piglets is 1:5. The ratio of adult horse to foal is 3:1. What fraction of the farm are babies (foals and piglets)? **$\frac{43}{60}$**
- 10) On a table there are some sandwiches. The ratio of sandwiches with white bread to brown bread is 10:3. Out of the sandwiches that are white, $\frac{2}{3}$ are vegetarian. Out of the sandwiches that are on brown bread, half are vegetarian. What fraction of the sandwiches are vegetarian? **$\frac{49}{78}$**
- 11) The ages of Adam, Ben and Caleb are in the ratio 5:7:11. Next year, they will be in the ratio 8:11:17. How old are they all now? **15, 21, 33**

- 3.) The ratio $10 : a$ is equivalent to $8 : (a + 10)$
Find the value of a
- 4.) The ratio $(x + 10) : x$ is equivalent to $5 : 10$
Find x
- 5.) The ratio $(b - 8) : 8$ is equivalent to $(b - 9) : 2$
Find b
- 6.) The ratio $(x + 2) : (x + 7)$ is equivalent to $7 : 4$
Find x
- 7.) The ratio $6 : (k + 3)$ is equivalent to $5 : (k - 7)$
Find k
- 8.) The ratio $(n + 7) : 2$ is equivalent to $(n - 6) : 9$
Find n

Functions

Videos 369, 370 on Corbettmaths

Question 16: Given $g(x) = \frac{3x + 1}{2}$

- (a) Find $g^{-1}(x)$
 (b) Calculate the value of $g^{-1}(11)$

Question 17: Given $f(x) = \frac{4x}{9} - 8$

- (a) Find $f^{-1}(x)$
 (b) Calculate the value of $f^{-1}(-10)$

Apply

Question 1: Given $f(x) = 5x + 7$ and $g(x) = 3x - 18$

Find the value of a such that $f(a) = g(a)$

Question 2: Given $f(x) = x^2 + 9$ and $g(x) = x + 21$

Find the values of a such that $f(a) = g(a)$

Question 3: Given $f(x) = \frac{x + 1}{3}$ and $g(x) = \frac{2}{x + 2}$

Find the values of a such that $f(a) = g(a)$

Question 4: Given $f(x) = x^2 + 4x - 1$

Express the following in the form $ax^2 + bx + c$

- (a) $f(x + 2)$ (b) $f(x - 1)$ (c) $f(2x)$
 (d) $f(3x)$ (e) $f(2x - 1)$ (f) $f(4x + 3)$

Functions

Videos 369, 370 on Corbettmaths

Question 5: The function f is such that $f(x) = kx + 7$

The function g is such that $g(x) = 3x - 2$

Given that $gf(1) = 34$

Work out the value of k

Question 6: The function g is such that $f(x) = \frac{kx + 2}{4}$

The function h is such that $g(x) = 2x + 5$

Given that $fg(4) = -9.25$

Work out the value of k

Question 7: For all values of x

$$f(x) = x^2 + 5$$

$$g(x) = x - 4$$

Solve $fg(x) = gf(x)$

Question 8: $f(x) = x^2 + 3x + 8$

Show that $f(x + 1) - f(x) = 2x + 4$

Answers



Click here



Scan here

9. DEF is an equilateral triangle.

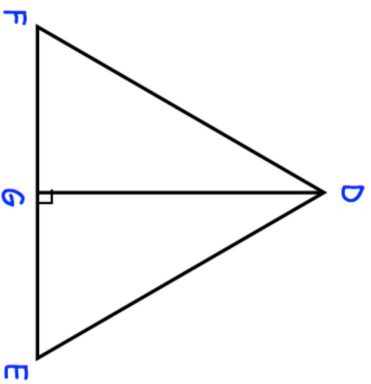

- G lies on EF.
DG is perpendicular to FE.
Prove $\triangle DFG$ is congruent to $\triangle DEG$.

(3)

10. ABC is an isosceles triangle in which $AC = BC$.
D and E are points on BC and AC such that $CE = CD$.

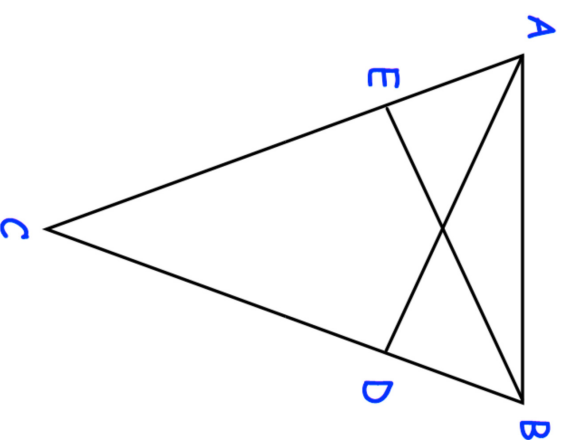

- Prove triangles ACD and BCE are congruent.

(4)

11. ABCD and LMNO are squares.
Angle CBL = x

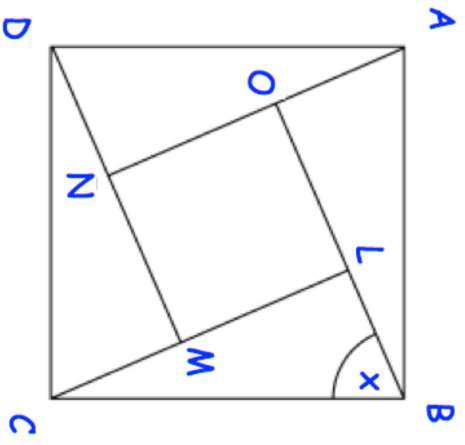

Prove that triangles ABO and CBL are congruent.

(4)

12. ABCD is a square, X is a point in the diagonal BD and the perpendicular from B to AX meets AC in Y.

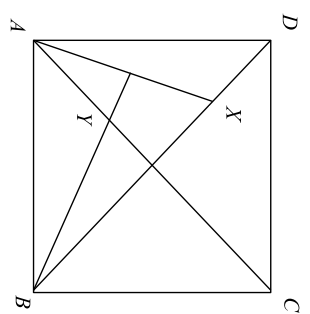

Prove that triangles AXD and AYB are congruent.

(4)

Error Intervals

Video 377 on www.corbettmaths.com

Examples



Workout

Click here

Scan here

Question 1: The mass of a coin is 8 grams to the nearest gram.
Complete the error interval for the mass of the coin

$$\dots\dots\dots \text{ g} \leq \text{mass} < \dots\dots\dots \text{ g}$$

Question 2: The distance between two cities is 900km to the nearest 100km.
Complete the error interval for the distance

$$\dots\dots\dots \text{ km} \leq \text{distance} < \dots\dots\dots \text{ km}$$

Question 3: Frank rounds a number, y , to the nearest ten.
His result is 20
Write down the error interval for y

Question 4: Lily rounds a number, y , to the nearest whole number.
Her result is 5
Write down the error interval for y

Question 5: Freya rounds a number, y , to one decimal place.
Her result is 6.4
Write down the error interval for y

Question 6: Oscar rounds a number, y , to the nearest integer.
His result is 100
Write down the error interval for y

Question 7: A number, n , is rounded to 1 decimal place.
The result is 1.3
Using inequalities, write down the error interval for n .

Question 8: A number, n , is rounded to 2 decimal places.
The result is 6.27
Using inequalities, write down the error interval for n .

Question 9: Elliott weighs 56.2kg.
This mass, m , is to the nearest 100g.
Write the error interval due to rounding.

Error Intervals

Video 377 on www.corbettmaths.com

Question 10: A number, x , is 21 when rounded to 2 significant figures.
Write down the error interval.

Question 11: A number, y , is 15000 when rounded to 2 significant figures.
Write down the error interval.

Question 12: A number, y , is 680000 when rounded to 3 significant figures.
Write down the error interval.

Question 13: The length of a line, l , was given as 2.8cm, truncated to 1 decimal place.
Complete the error interval for l

$$\dots\dots\dots \text{ cm} \leq l < \dots\dots\dots \text{ cm}$$

Question 14: A number, y , is 0.37 when truncated to 2 decimal places.
Complete the error interval for y

$$\dots\dots\dots \leq y < \dots\dots\dots$$

Question 15: A number, n , is truncated to 1 decimal place.
The result is 18.1
Using inequalities, write down the error interval for n .

Question 16: A number, n , is truncated to 3 decimal places.
The result is 4.066
Using inequalities, write down the error interval for n .

Apply

Question 1: The length of each side of a regular hexagon is 4.7cm to 1 decimal place.
Write the error interval for the perimeter, P

Question 2: Grace and George complete a crossword.
It takes Grace 9 minutes to complete the crossword to the nearest minute.
It takes George 11 minutes to complete the crossword to the nearest minute.

Show that the total time for both people to complete the crossword could be 20 minutes 50 seconds.

Question 3: A man jogs 200 metres to the nearest 10 metres.
It takes him 30 seconds to the nearest 10 seconds.

Work out the error interval for his speed, s .



Error Intervals

Video 377 on www.corbettmaths.com

Question 4: A number, x , is 1.92 when truncated to 2 decimal places.
Matthew has been asked to write down the error interval.
This is his answer.

$$1.915 \leq x < 1.925$$

Explain why Matthew is wrong.

Question 5: A number, n , is rounded to 3 significant figures.
The result is 7500
Norris has been asked to write down the error interval for n .
This is his answer.

$$7450 < x < 7550$$

Explain why Norris is wrong.

Answers

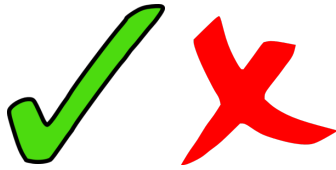

Click here



Scan here

- Question 6: A helicopter leaves A and flies 40 miles due east. Then the helicopter flies 10 miles due south and arrives at B. Work out the bearing of B from A.
- Question 7: A boat leaves a port and sails 55km due west and then 30km due north and arrives at an oil rig. What is the bearing of the oil rig from the port?
- Question 8: Shown is an isosceles triangle. Calculate its area.

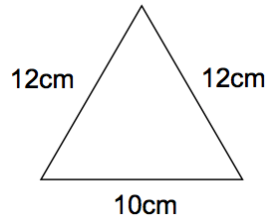

- Question 9: Shown is a rhombus of side length 10cm. Calculate its area.

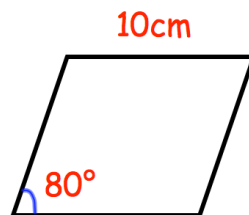

- Question 10: Can you spot any mistakes in the question below?

Find the size of the angle x .

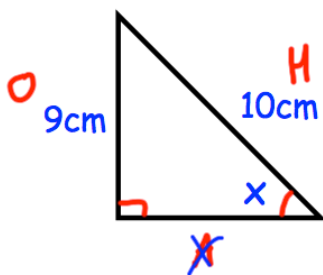

$$\begin{aligned} \sin x &= \frac{9}{10} \\ \sin x &= 0.9 \\ x &= \sin 0.9 \\ x &= 0.016^\circ \end{aligned}$$

Answers

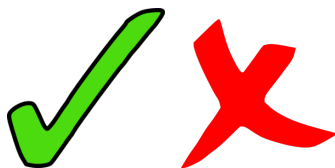

Click here



Scan here

Box Plots

Videos 149 and 150 on www.corbettmaths.com

Question 4: Draw a box plot for each set of data

- (a) 8, 10, 13, 14, 14, 15, 15, 16, 18, 19, 21, 22, 24, 29, 35
- (b) 40, 80, 90, 90, 100, 120, 130
- (c) 5.9, 7.3, 7.8, 8, 8.4, 8.7, 8.9, 8.9, 8.9, 9, 9, 9.1, 9.1, 9.3, 9.5, 9.6, 9.9, 10.5, 10.9

Question 5: Compare the distributions of each pair of box plots below.

(a)

7A results

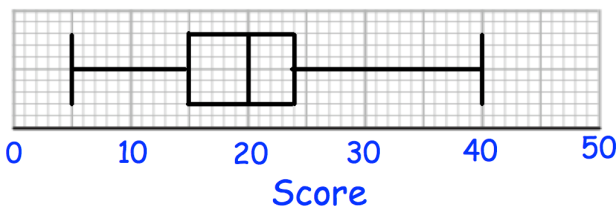

(b)

Time taken to complete puzzle - Children

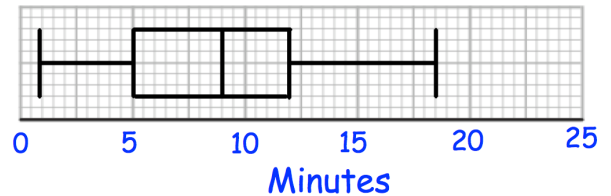

7B results

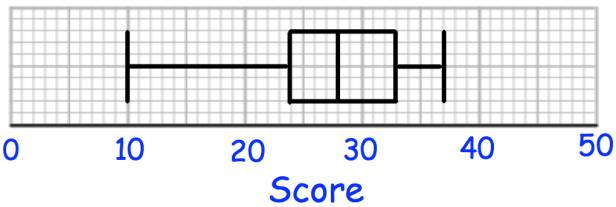

Time taken to complete puzzle - Adults

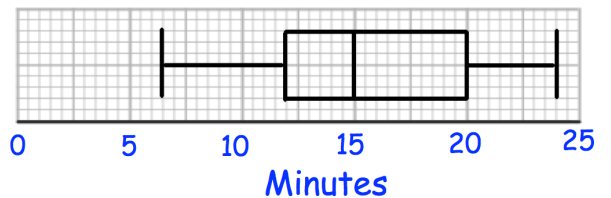

(c)

Length of red squirrels

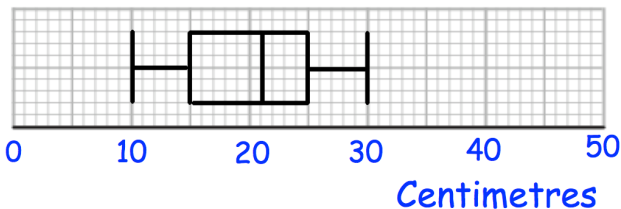

(d)

Reaction Times - Group A

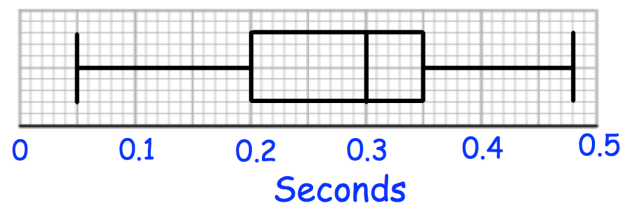

Length of grey squirrels

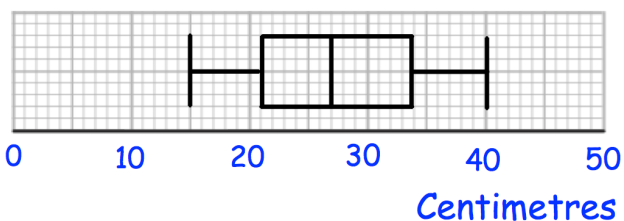

Reaction Times - Group B

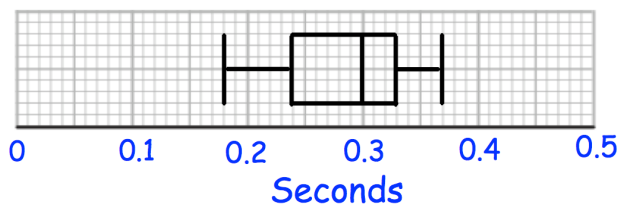

Box Plots

Videos 149 and 150 on www.corbettmaths.com

- Question 3: Mr Jones is an estate agent on the Isle of Man. He has created this table to show information about the prices of houses he has sold. Explain how you know he has made a mistake.

Median	£375,000
Range	£235,000
Interquartile Range	£590,000

- Question 4: The box plot show information about the masses of apples in a crate.

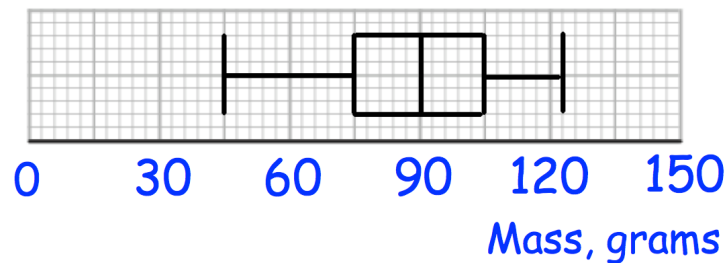

Jack is going to select apples at random from the crate. After selecting each apple, he records its mass and returns it to the crate before picking another. Work out the probability that:

- Jack picks two apples, both under 75g
- Jack picks two apples, both over 90g
- Jack picks two apples, both over 105g
- Jack picks two apples, one under 90g and one over 105g
- Jack picks three apples, all over 105g
- Jack picks three apples, two over 105g and one under 75g.

Answers



Click here



Scan here

Product Rule for Counting

Video 383 on www.corbettmaths.com

- Question 6: Oliver picks a 4-digit **even** number that is greater than 3000.
The second digit is a multiple of 4.
How many different numbers could Oliver pick?
- Question 7: Sophia is creating a 6-digit code to lock her iPad.
She only uses digits greater than 2.
She only uses each digit once.
How many possible codes can Sophia create?
- Question 8: In a class, there are 10 boys and 9 girls.
The teacher has been asked to pick one boy and one girl to win a prize.
How many possible pairs of students can the teacher pick?
- Question 9: Jason picks a 5-digit number that is less than 80000.
The first digit is odd.
The fourth and fifth digits are equal.
How many different numbers can Jason pick?
- Question 10: A headteacher wants to survey two Year 7 students.
There are 100 students in Year 7.
How many possible pairs of students can the headteacher pick?
- Question 11: How many even numbers greater than 40000 can be created using these digits?

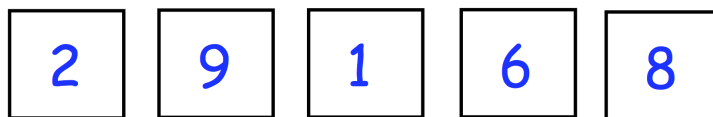

Apply

- Question 1: On a school trip, students are given a packed lunch.
The students can choose one piece of fruit and one snack.
There are 8 different pieces of fruit and some different snacks.
Altogether there are 104 different ways to choose one piece of fruit and one snack
How many different snacks are there?

Product Rule for Counting

Video 383 on www.corbettmaths.com

Question 2: At a summer camp, children pick a morning, an afternoon and an evening activity.

There are 4 morning and 7 evening activities to pick from.

Altogether there are 224 different ways to choose their activities.

How many afternoon activities are there?

Question 3: In a gym there are

12 exercise classes on a Monday

13 exercise classes on a Wednesday

7 exercise classes on a Friday

Katie is going to attend either

- or a class on Monday and a class on Friday
- or a class on Wednesday and a class on Friday
- or a class on Monday, Wednesday and Friday

Work out how many different ways there are to pick which exercises classes Katie is going to attend.

Question 4: A group of 10 people enter a room.
Each person shakes hands, once, with all the other people in the room.

How many handshakes are there in total?



Question 5: A pizza parlour sells 9 different toppings.

Michael orders a pizza with 2 different toppings.

(a) How many different pizzas can he choose from?

Beth orders a pizza with 3 different toppings.

(b) How many different pizzas can she choose from?

John orders a pizza with 4 different toppings.

(c) How many different pizzas can he choose from?

Answers



Click here



14.

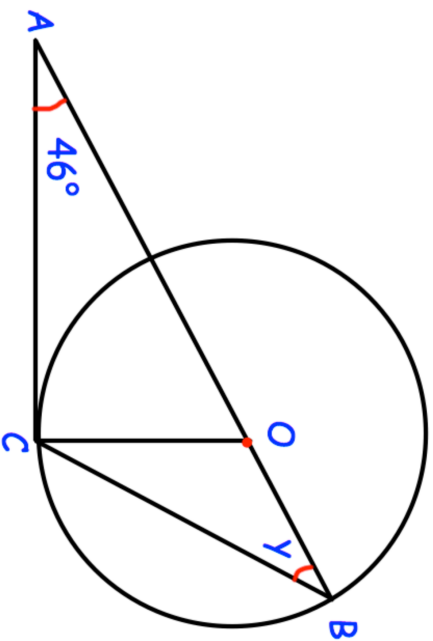

AOB is a straight line.
 B and C are points on the circumference of a circle, centre O .
 AC is a tangent to the circle.

Work out the size of the angle y .

.....
(4)

15.

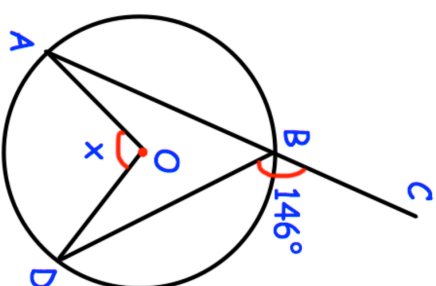

Shown is a circle with centre O .
 ABC is a straight line.
Angle CBD is 146° .

Find the size of angle AOD .

.....
(3)

16. RS is a tangent to the circle at R.

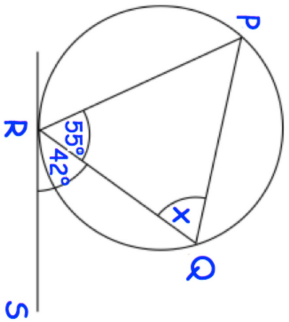

Calculate the value of x .

Give reasons for your answer.

.....°
(3)

17. AC and BC are tangents to the circle with centre O.

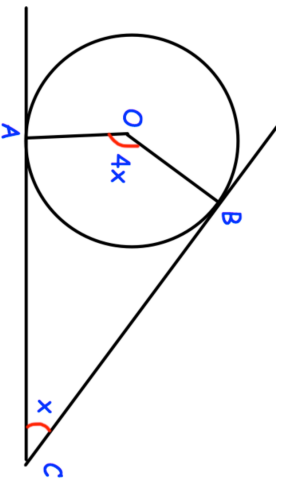

Find the size of x .

.....°
(3)

18. A, B and C are points on the circumference of a circle with centre O.

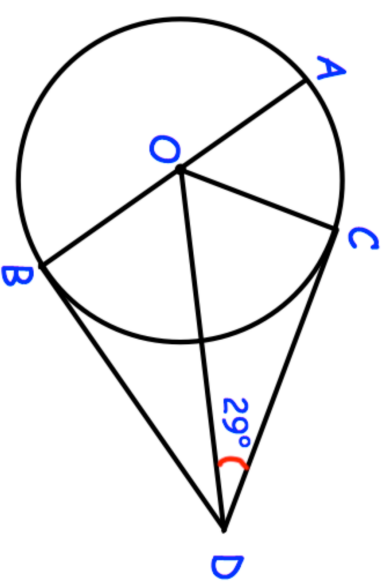

AOB is a diameter of the circle.

CD and BD are tangents to the circle.

Angle CDO = 29°

Work out the size of angle AOC.

Give reasons for each stage of your working.

.....°
(4)

19. DEFG is a cyclic quadrilateral.
 PDQ is a tangent at D.
 O is the centre of the circle.
 DEF is an isosceles triangle.

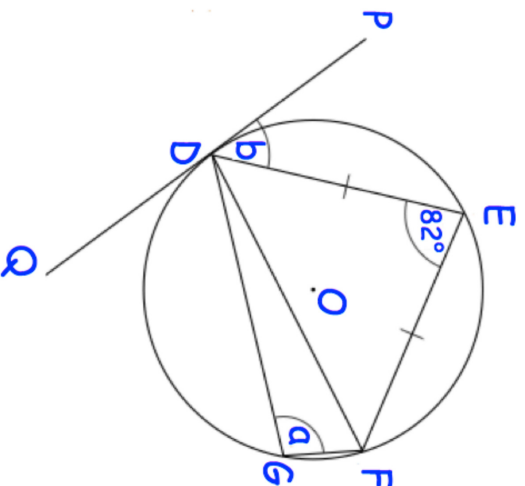

- (a) Work out the value of a.
 (b) Work out the value of b.
 (c) Write down the name of the circle theorem used in part (b)

.....°
 (2)

.....°
 (3)

.....
 (1)

- 20.

Shown is a circle, centre O.
 B, C and D are points on the circumference.

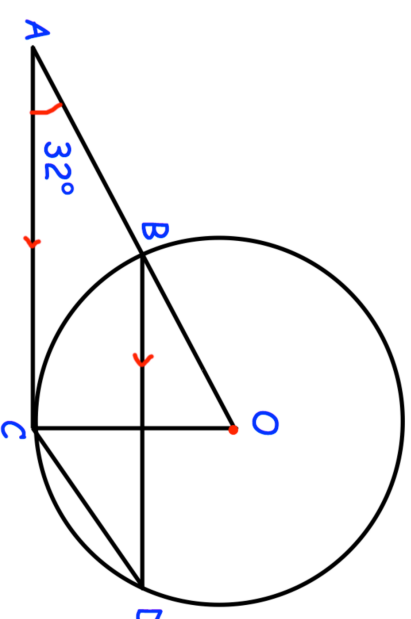

ABO is a straight line.
 AC is a tangent to the circle.

- (a) Work out angle AOC.
 (b) Work out angle BDC.
 (c) Work out angle ACD.

.....°
 (2)

.....°
 (3)

.....°
 (1)

21. PQRS is a cyclic quadrilateral.
 APB is a tangent to the circle at P.
 PQ is parallel to SR.
 Angle SPB = 35° and angle PSQ = 80°

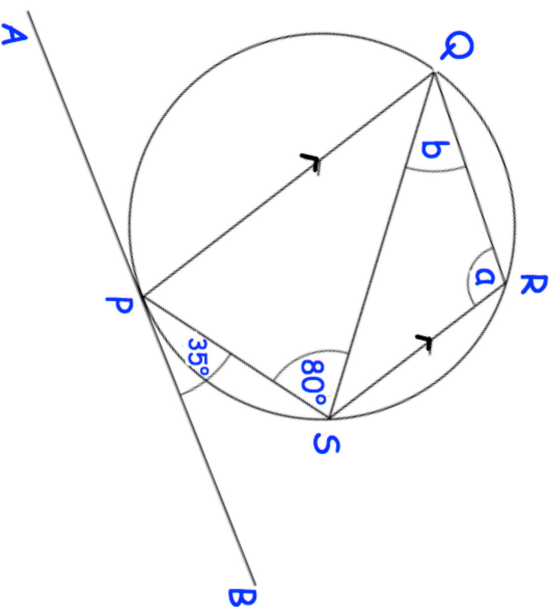

- (a) Work out the size of angle QRS.
- (b) Work out the size of angle ROS.

.....^o (4)

.....^o (2)

- 22.

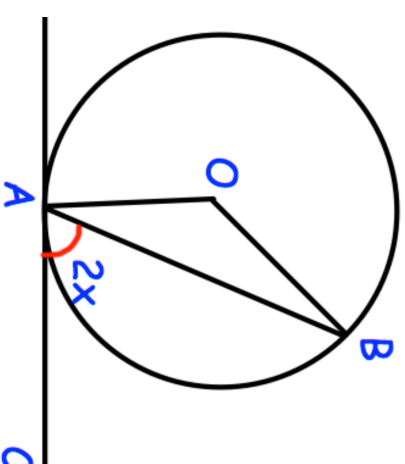

- A and B are points on the circumference of a circle, centre O.
 CA is a tangent to the circle.
 Angle CAB = $2x$
- Prove that angle AOB = $4x$
 Give reasons for each stage of your working.

(4)

1.

[4 marks]

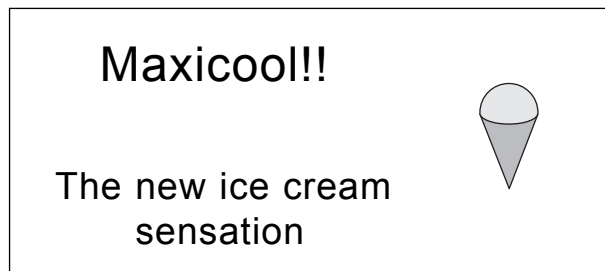

A Maxicool consists of a cone full of ice cream with a hemisphere of ice cream on top.
The radius of the hemisphere is 3 cm.
The radius of the base of the cone is 3 cm.
The height of the cone is 10 cm.

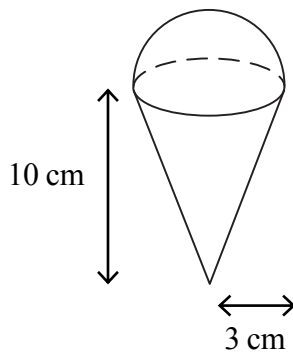

Diagram **NOT** accurately drawn

Calculate the total volume of ice cream in a Maxicool.
Give your answer correct to 3 significant figures.

2.

[5 marks]

A solid is made from a cylinder and a hemisphere.
The cylinder has radius 1.5 cm and height 4 cm.
The hemisphere has radius 1.5 cm.

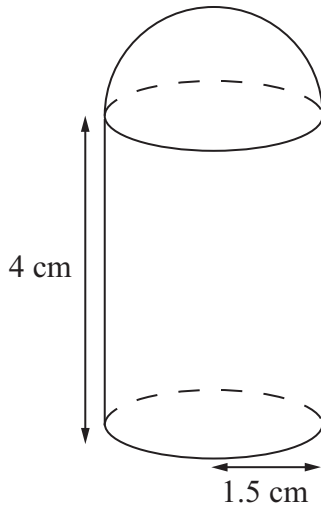

Diagram **NOT**
accurately drawn

Work out the total volume of the solid.
Give your answer correct to 3 significant figures.

..... cm³

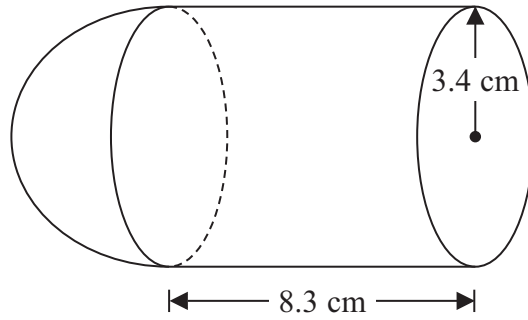

Diagram **NOT**
accurately drawn

The diagram shows a shape made from a solid cylinder and a solid hemisphere.
The cylinder has a radius of 3.4 cm and a length of 8.3 cm.
The hemisphere has a radius of 3.4 cm.

Calculate the total surface area of the solid shape.
Give your answer correct to 3 significant figures.

..... cm²

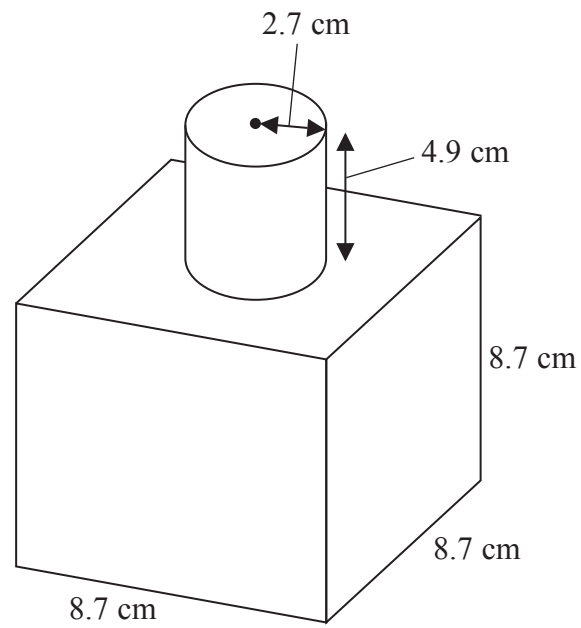

Diagram **NOT**
accurately drawn

The diagram shows a shape made from a solid cube and a solid cylinder.
The cube has sides of length 8.7 cm.
The cylinder has a radius of 2.7 cm and a height of 4.9 cm.

Calculate the total surface area of the solid shape.
Give your answer correct to 3 significant figures.

..... cm²

The diagram shows a sphere and a cone.

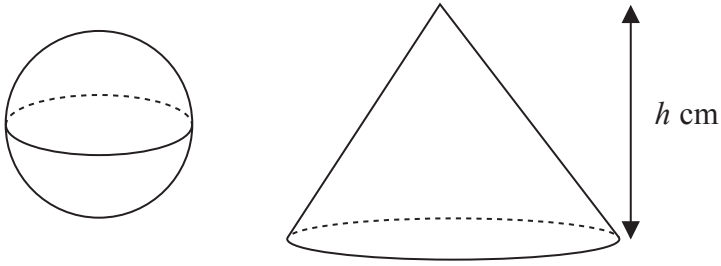

Diagram **NOT**
accurately drawn

The cone has height h cm.

The radius of the base of the cone is 3 times the radius of the sphere.

Given that the volume of the sphere is equal to the volume of the cone,
find an expression for the radius of the sphere in terms of h .

Give your expression in its simplest form.

The diagram shows two solid shapes, shape **A** and shape **B**.

Shape **A** is made of a hemisphere and a cone.

Shape **B** is a cylinder.

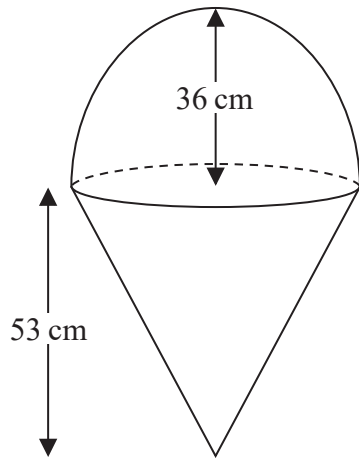

A

Diagram **NOT**
accurately drawn

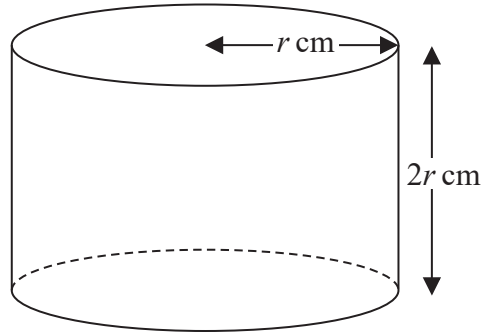

B

For shape **A**

radius of the hemisphere is 36 cm
radius of the base of the cone is 36 cm
height of the cone is 53 cm

For shape **B**

radius of the cylinder is r cm
height of the cylinder is $2r$ cm

The volume of shape **A** = the volume of shape **B**

Calculate the height of shape **B**.

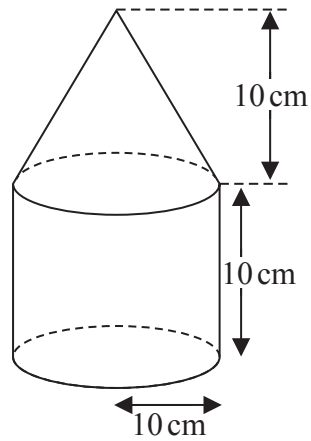

Diagram **NOT**
accurately drawn

The diagram shows a solid shape made from a cone on top of a cylinder.

The cone has a radius of 10 cm and a height of 10 cm.

The cylinder has a radius of 10 cm and a height of 10 cm.

The centre of the base of the cone coincides with the centre of the top face of the cylinder.

The total surface area of the solid is $A \text{ cm}^2$

Show that $A = (300 + 100\sqrt{2})\pi$

The diagram shows a cylinder and a sphere.

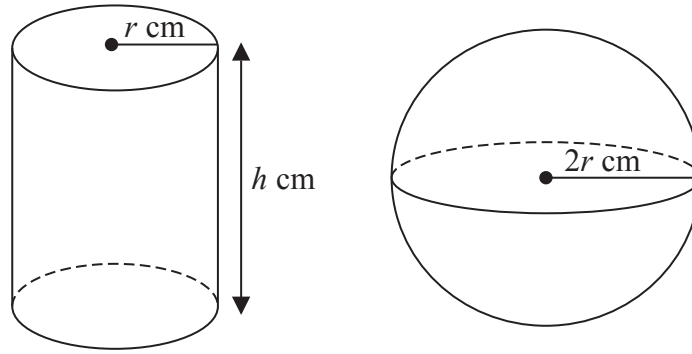

Diagram **NOT**
accurately drawn

The cylinder has radius r cm and height h cm.

The sphere has radius $2r$ cm.

The volume of the cylinder is equal to the volume of the sphere.

Find an expression for h in terms of r .

Give your answer in its simplest form.

.....

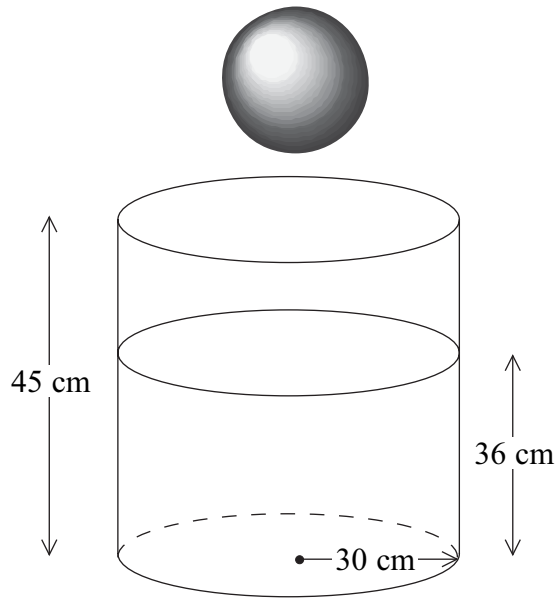

Diagram **NOT**
accurately drawn

A cylindrical tank has a radius of 30 cm and a height of 45 cm.
The tank contains water to a depth of 36 cm.

A metal sphere is dropped into the water and is completely covered.
The water level rises by 5 cm.

Calculate the radius of the sphere.

..... cm

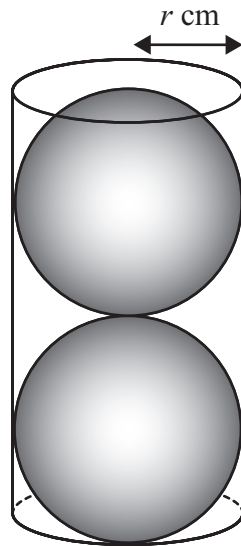

Diagram **NOT**
accurately drawn

Two solid spheres, each of radius r cm, fit exactly inside a hollow cylinder.

The radius of the cylinder is r cm.

The height of the cylinder is equal to $4r$ cm.

The volume of the space inside the cylinder, not occupied by the spheres, is $\frac{125}{6}\pi$ cm³

Calculate the value of r .

Show your working clearly.

$r = \dots\dots\dots$

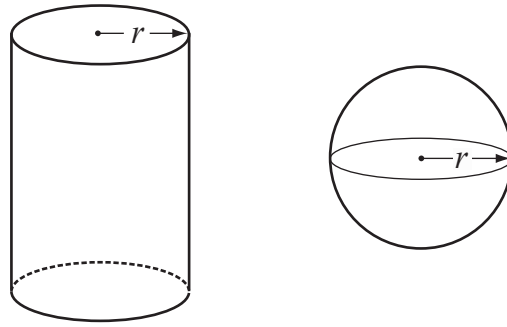

Diagram **NOT**
accurately drawn

The diagram shows a solid cylinder and a solid sphere.
The cylinder has radius r .
The sphere has radius r .

Given that $\frac{\text{Total surface area of cylinder}}{\text{Surface area of sphere}} = 2$

find the value of $\frac{\text{Volume of cylinder}}{\text{Volume of sphere}}$

.....

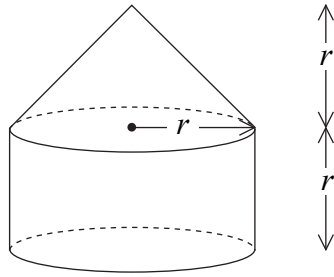

The diagram shows a solid made from a cone and a cylinder.

The cylinder has radius r and height r .

The cone has base radius r and height r .

- (a) Show that the total volume of the solid is equal to the volume of a sphere of radius r .

(2)

The curved surface area of a cylinder with base radius r and height h is $2\pi rh$.

The curved surface area of a cone with base radius r and slant height l is πrl .

- (b) Show that the **total** surface area of the above solid is greater than the surface area of a sphere of radius r .

(3)

Apply

Question 1: ABC is a triangle.

Describe fully a **single** transformation of ABC so that:

- (a) None of the vertices are invariant.
- (b) Exactly one vertex is invariant.
- (c) Exactly two vertices are invariant.

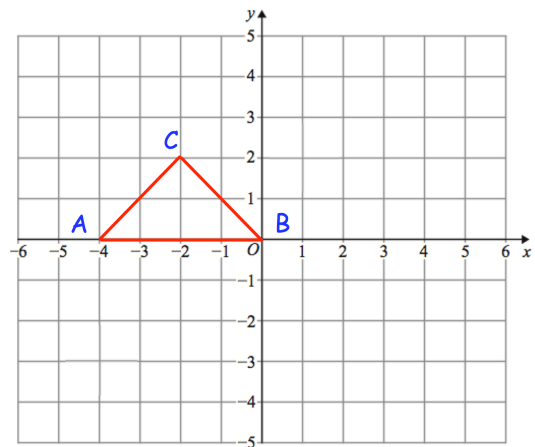

Question 2: Here is triangle ABC

Olivia says "if ABC is reflected in the line $x = -3$ there is one invariant point."

Amelia says "if ABC is reflected in the line $y = -2$ there are two invariant points."

Isla says "if ABC is reflected in the line $x = 1$ there are two vertices that are invariant."

Which student is incorrect? Explain your answer.

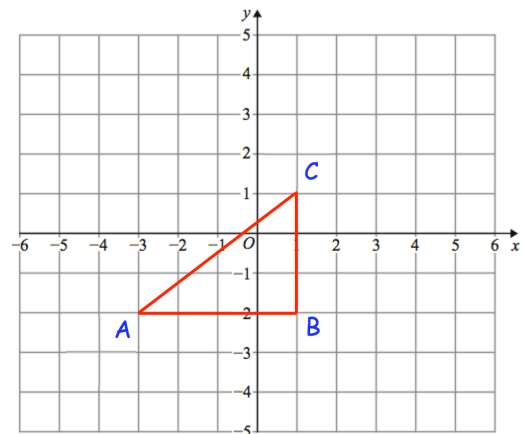

Question 3: Here is a sketch of triangle ABC.

Describe fully a **single** transformation of ABC so that all the points on AC are invariant and the point B is not invariant.

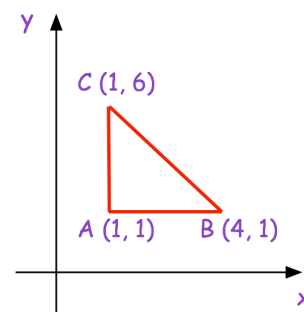

Question 4: Here is shape ABCDEF

Describe fully **single** transformations so that from the six vertices:

- (a) only vertices B and C are invariant.
- (b) only vertex F is invariant.
- (c) only vertices B, D and F are invariant.

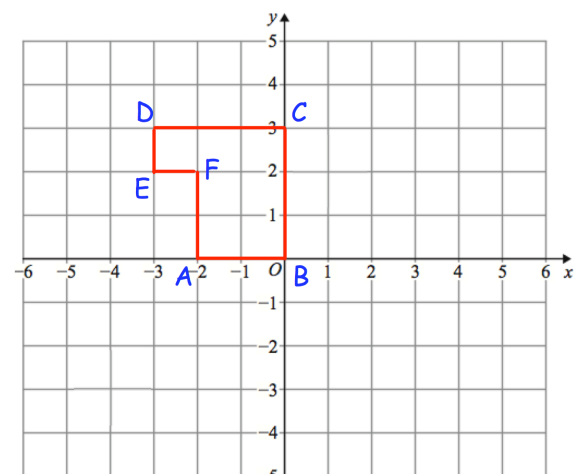

Invariant Points

Video 392 on www.corbettmaths.com

Question 5: Here is quadrilateral ABCD

ABCD is reflected in the line $x = -1$
 followed by a reflection in the line $y = -x$
 followed by a rotation of 180° about $(-1, -1)$

Which of the vertices are invariant?

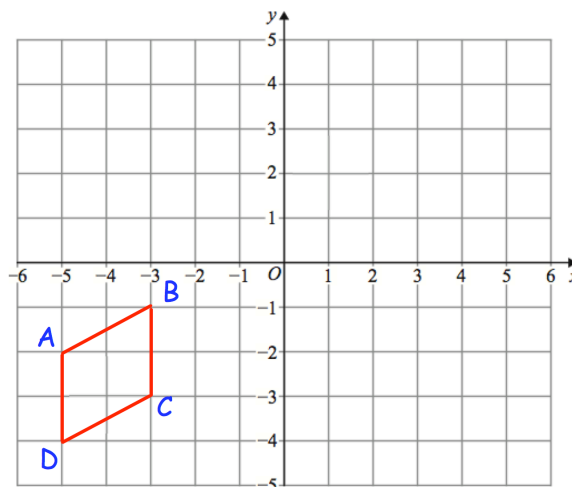

Question 6: Shown is triangle ABC

ABC is rotated 180° about $(-1, 2)$ and then
 translated by the vector $\begin{pmatrix} 2 \\ -4 \end{pmatrix}$

Write down the coordinate of the invariant point.

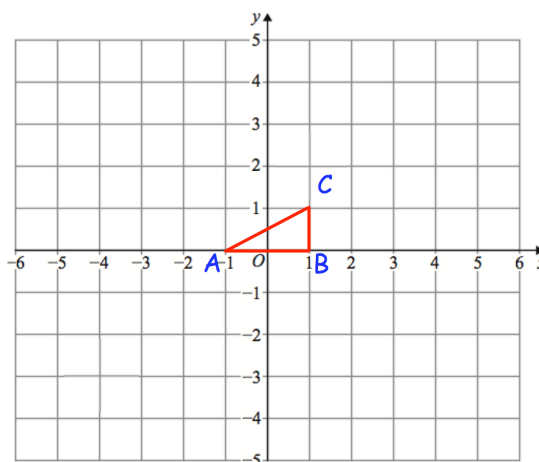

Answers

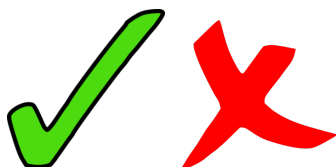

Click here



Scan here

's

**GCSE MATHEMATICS
REVISION PACK**